

GTF-1100T

Instruction Manual

Revision: 1.4

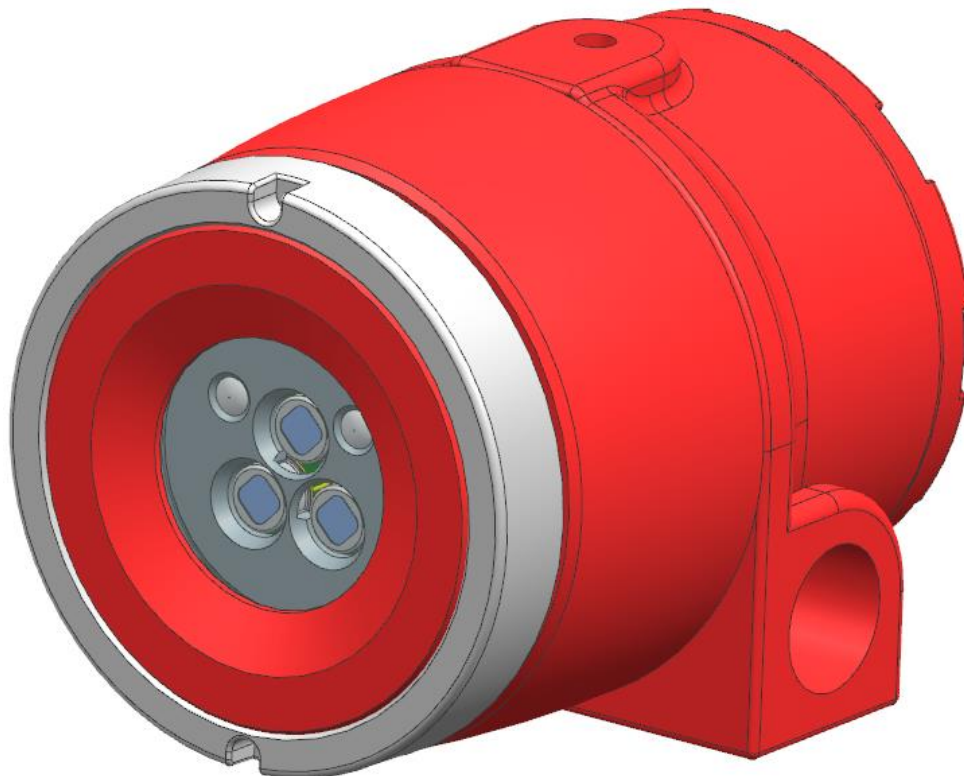

For proper use, please read this manual carefully!

Copyright (c)GASTRON, Co., LTD. All rights reserved.

We deeply appreciate your purchase of GASTRON products.

GASTRON, a company specialized in flame & gas detector and F&G monitoring system, has enjoyed a great reputation from numerous consumers for its superior quality and user convenience. We, at GASTRON, will always endeavor to let consumers gain an easy access to our products at all time and have exerted ourselves to ceaselessly develop and research for flame & gas detectors catering to consumers' satisfaction.

From now on, please solve all the troubles related to flame & gas detectors with products from GASTRON. We will be committed to provide you with your satisfaction.

This instruction manual records the operating methods, simple maintenance methods and other useful guidelines regarding GTF-1100T. Please read carefully and safekeeping this manual will be helpful should you have questions during operation.

Should problems occur after buying our products, please contact the details below:

- Address: 23, Gunpocheomdansaneop 1-ro, Gunpo-si, Gyeonggi-do, 15881, Rep. of Korea
- Tel: 031-490-0800
- Fax: 031-490-0801
- URL : www.gastron.com
- e-mail : gastron@gastron.com

NOTE

- You are kindly requested to get your flame detector inspected at least once in six months in order to ensure a precise operation of the product.
- Not getting periodic inspections done may result in malfunctioning of the product due to aging of the sensor unit.
- Disassembly of this equipment should be performed by a professional with expertise in flame detector.
- Please refer to our technical department, website or write an e-mail to

us for specifics regarding inspection of flame detector.

This product and manual subject to change without prior notice
for improvement and user convenience of the product.

TABLE OF CONTENTS

1. Overview 7

2. Features 7

3. Product Order Number 8

4. Specifications 9

 4.1. General Specifications 9

 4.2. Mechanical Specifications 9

 4.3. Electrical Specifications (Standard Type) 10

 4.4. Environmental Specifications 10

 4.5. Option Material 11

5. Detector Performance 11

 5.1. Fuel and distance 11

 5.2. F.O.V. (Field of View) 11

 5.3. False Alarm Immunity 12

 5.4. Flame response in the presence of False alarm source 13

 5.5. Output Signal 15

 5.6. Detector Status 16

 5.7. Latching 17

 5.8. B.I.T. (Built In Self Test) 17

 5.9. Trouble Alarm 17

5.10. 0~20mA Analog Current Output.....	19
5.11. RS-485 Address Settings.....	19
6. Installation.....	21
6.1. Opening Body Cap.....	21
6.2. Terminal PCB Configuration.....	22
6.3. Cable Wiring.....	23
6.4. Length of Installed Cable	25
6.5. Wiring.....	27
6.5.1. Relay Wiring.....	27
6.5.2. Configuration of Analog Output Cable.....	28
6.5.3. Configuration of RS-485 Cable	29
6.6. Blanking Cable Entry	29
7. Names and Description of Parts.....	30
7.1. Front Configuration.....	30
7.2. Parts	31
8. Dimensions	33
8.1. GTF-1100T Dimensions	33
8.2. GTF-1100T + Weather Proof Cover + Bracket Assembly Dimensions	34
8.1. GTF-1100T Certification Label (Approval to FM).....	35
8.2. GTF-1100T Certification Label (Approval to ATEX/IECEX/NEPSI).....	37
9. Operation.....	38
9.1. Energizing.....	38
9.2. Default Function Settings.....	38
9.3. Auto B.I.T	38
9.4. Test using FS-320 Simulator.....	39
10. Approvals.....	39
10.1. CE.....	39
10.2. FM.....	41
10.3. ATEX/ IECEX/ NEPSI	41
11. Accessories.....	42
11.1. Flame Simulator (Part No. FS-320).....	42
11.1.1. Overview	42
11.1.2. Features.....	42
11.1.3. Operation.....	42
11.1.4. Trouble Indication.....	43

- 11.1.5. General Specifications..... 43
- 11.1.6. Mechanical Specifications 43
- 11.1.7. Electrical Specifications (Standard Type)..... 43
- 11.1.8. Environmental Specifications 43
- 11.1.9. Charger Specifications 44
- 11.1.10. Names of Parts 44
- 11.1.11. Charging the Battery..... 45
- 11.1.12. EMC..... 45
- 11.2. Weather Proof Cover (Part No. FWP-1000)..... 47
- 11.3. Weather Proof Cover Assembly 48
- 11.4. Mounting Bracket Dimension (Part No. FMB-1000)..... 49
- 11.5. Bracket Assembly..... 50
- 11.6. Bracket Tilt..... 52
- 11.7. Cable Grand Direction..... 53
- 12. Precautions during Installation 54
- 13. Warning..... 55
- 14. Revision Records 57

1. Overview

GTF-1100T Flame Detector was developed to prevent beforehand the big accidents due to fire which can break out in all industrial sites.

It can be installed in all industrial sites that fire may outbreak, and should it be installed at places with risk of fire it will detect permanently and continuously.

Three types of hypersensitive sensors, one to detect wavelengths of infrared wave which cannot be seen by naked eye, were inserted to detect fire fast and minimize the false alarm due to interference.

LED installed in the product displays the situations and prints out 0-20mA analog current output, RS-485 communication signal, alarm relay, and trouble relay contact signal.

2. Features

- Triple IR Sensor
- Detection Distance: 60m
- FOV(Field of View): Horizontal: 100°
Vertical: 100°
- Automatic & Manual B.I.T.(**B**uilt **I**n **S**elf **T**est)
- Interface
 - Alarm Dry contact Relay(De-Energized)
 - Trouble Dry contact Relay(Energized)
 - RS-485 Interface (MODBUS RTU)
 - 0~20mA Analog Current Output
- Indicator
 - Status LED (Bi-Color: RED & GREEN), Alarm LED (RED)
- Approval
 - EMC: EN50130-4, EN61000-6-4
 - FM3260
 - ✓ Class I Division1 Groups A B C and D
 - ✓ Class II, III Division 1 Groups E F and G
 - ATEX/IECEX/NEPSI
 - ✓ Ex db IIC T6...T4 Gb
 - ✓ Ex tb IIIC T80°C Db IP66/67

- Accessory
 - Flame Simulator (Part No. FS-320)
 - Weather Proof Cover (Part No. GWP-1000)
 - Mounting Bracket (Part No. FMB-1000)

3. Product Order Number

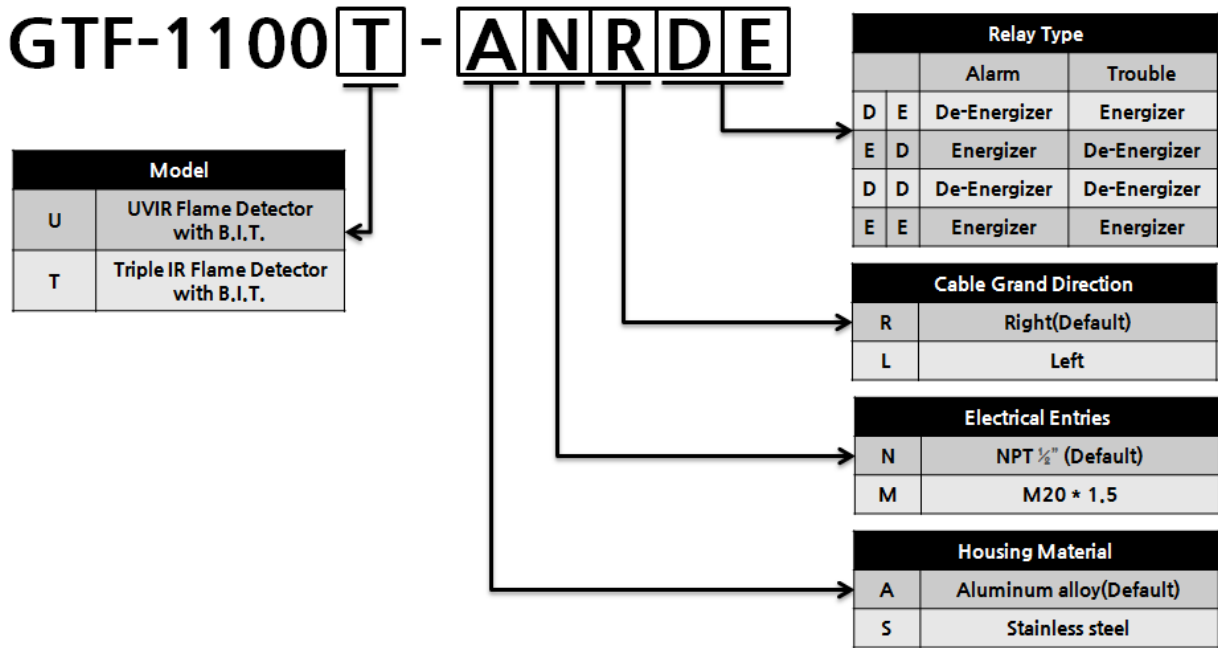

Ex) GTF-1100T-APRDE

- Model: GTF-1100T Triple with B.I.T.
- Housing Material: Aluminum alloy
- Electrical Entries: NPT ½"
- Cable Grand Direction: Right (When seen from front of detector, refer to Table 26)
- Alarm Relay Type: De-Energizer
- Trouble Relay Type: Energizer

4. Specifications

4.1. General Specifications

I T E M S	S P E C I F I C A T I O N	
Wavelengths	Multi IR Channel	3.8 - 5.5 μ m
Detection Distance	60m (0.1 m ² n-Heptane pan fire)	
Field of View	Horizontal: 100°, Vertical: 100°	
Typical Response Time	Typical 7.9sec (6.1sec ~ 7.9sec) (0.1 m ² n-Heptane pan fire / 60m)	
Indicator	Status LED(Bi-Color: Red & Green) Alarm LED(Red)	
Output	0-20mA Analog Current Output	
	1 Alarm Relay, 1 Trouble Relay SPST (1A at 30VDC or 0.3A at 125VAC)	
	RS-485 Interface (MODBUS RTU)	
Warranty	2 Years	

4.2. Mechanical Specifications

I T E M S	S P E C I F I C A T I O N	
Explosion Proof type	Explosion Proof enclosure	
Approvals Classification	FM	Class I Division1 Groups A B C and D Class II, III Division 1 Groups E F and G
	ATEX/IECEX/NEPSI	Ex db IIC T6...T4 Gb Ex tb IIIC T80°C Db IP66/67
Degree of protection	IP66, IP67	
Dimension(GTF-1100U)	76(W) ×76(H) × 96.5(D) mm	
Dimension (GTF-1100U + Assembly)	150(W) x 126(H) x 240(D) mm	
Weight (Detector Only)	App. 0.7kg	
Cable inlet	FM	½" NPT

	ATEX/IECEX/NEPSI	½" NPT, M20 * 1.5
Housing Material	Aluminum alloy or Stainless steel	

4.3. Electrical Specifications (Standard Type)

I T E M S	S P E C I F I C A T I O N	
Operating Power	Nominal operating voltage	24V DC / 96mA Max
	Min. Max. operating voltage	32V DC / 75mA Max 18V DC / 122mA Max
Power consumption	Stand by (Without B.I.T.)	1.3W @32VDC 1.2W @24VDC 1.1W @18VDC
	Stand by (With B.I.T.)	2.4W @32VDC 2.3W @24VDC 2.2W @18VDC
	Alarm	1.4W @32VDC 1.3W @24VDC 1.2W @18VDC
Wiring Specifications	CVVSB with shield 0.75sq * 10C (KFI Only)	
EMC Protection	EN50130-4, EN61000-6-4	

4.4. Environmental Specifications

I T E M S	S P E C I F I C A T I O N	
Ambient Temperature	FM	T6 = -40°C ≤ Ta ≤ 60°C T5 = -40°C ≤ Ta ≤ 75°C
	ATEX/IECEX/NEPSI	T6 = -40°C ≤ Ta ≤ 60°C T5 = -40°C ≤ Ta ≤ 75°C T4 = -40°C ≤ Ta ≤ 85°C T80°C : -40°C ≤ Ta ≤ 60°C
Operation Temperature	-40°C ~ 75°C	
Storage Temperature	-50°C ~ 80°C	
Operation Humidity	Up to 95% RH (Non-condensing)	

4.5. Option Material

I T E M S		S P E C I F I C A T I O N
Flame Simulator	FS-320	Aluminum alloy
Weather Proof Cover	FWP-1000	Aluminum alloy
Mounting Bracket	FMB-1000	Aluminum alloy

[Table 1: Specification]

5. Detector Performance

5.1. Fuel and distance

Fuel	Distance (m)
n-Heptane	60

[Table 2: Fuel and distance]

5.2. F.O.V. (Field of View)

➤ Horizontal: 100°

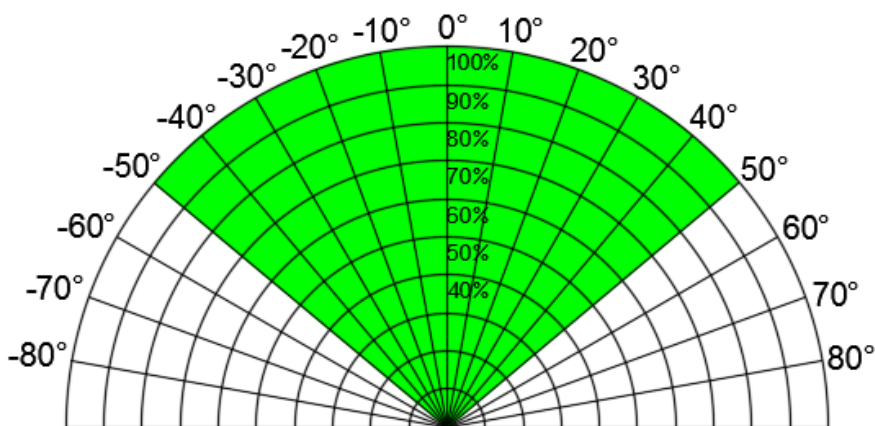

[Figure 1: Horizontal]

➤ Vertical: 100°

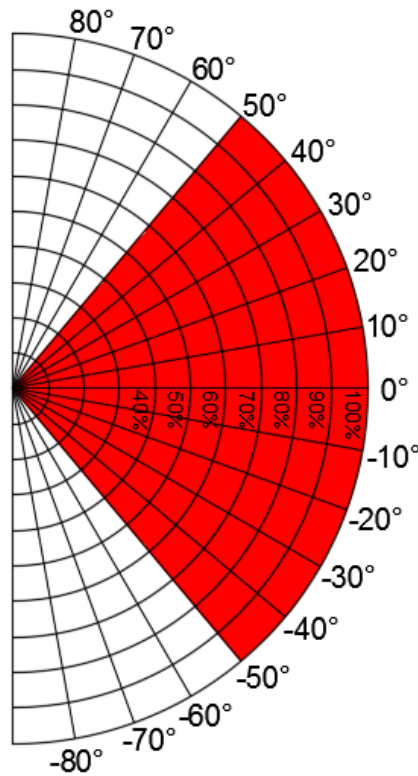

[Figure 2: Vertical]

5.3. False Alarm Immunity

- There are several elements that lead to false alarm and may influence on the detection of fire as below. The table below lists the conditions where detector does not recognize as fire.

False Alarm Source	Modulated Response(m)	Unmodulated Response(m)
Direct or reflected sunlight	IAD	IAD
Arc welding DC (190 ± 20) A, 7014 rod	1	1
Grinding metal	1	1
Fluorescent lamp 35W * 2	IAD	IAD
Halogen lamp 1kW	IAD	IAD
Halogen lamp 500W	IAD	IAD

Radiation Heater 1.5kW with Fan	IAD	IAD
Radiation Heater 3kW	IAD	IAD
Incandescent light 300W	IAD	IAD
Mercury vapor lamp 175W	IAD	IAD
Sodium lamp 70W	IAD	IAD
Lit cigarette	IAD	IAD
Lit cigar	IAD	IAD
Match, Wood, Stick including flare up	1	1
Flashlight(MX 991/U, Pelican Stealth Lite 2460)	IAD	IAD

[Table 3: False Alarm Source list]

- IAD = Immune at Any Distance

5.4. Flame response in the presence of False alarm source

- The following table shows the detection distances when False Alarm and Flame are together.

Distance between the False alarm source and the detector(m)		Distance between the Flame and the detector			
		Modulated Response		Unmodulated Response	
		Distance(m)	Time(sec)	Distance(m)	Time(sec)
Direct sunlight	-	2.6	13.0 (9.7 ~ 13.0)	40	12.6 (7.4 ~ 12.6)
Reflected sunlight	7	11	18.7 (4.9 ~ 18.7)	40	11.5 (8.6 ~ 11.5)
Arc welding DC (190 ± 20) A, 7014 rod	5	27	8.5 (7.3 ~ 8.5)	60	23.3 (5.8 ~ 23.3)
Grinding metal	1.5	25	25.1 (14.2 ~ 25.1)	60	6.5 (5.2 ~ 6.5)
Fluorescent lamp 35W * 2	2	25	30.0	60	7.4

			(9.4 ~ 30.0)		(4.9 ~ 7.4)
Halogen lamp 1kW	5	14	21.5 (9.8 ~ 21.5)	60	8.1 (4.4 ~ 8.1)
Halogen lamp 500W	5	25	9.2 (6.5 ~ 9.2)	60	11.0 (6.2 ~ 11.0)
Radiation Heater 1.5kW with Fan	5.5	10	16.3 (5.6 ~ 16.3)	60	8.3 (5.7 ~ 8.3)
Radiation Heater 3kW	6	14	13.7 (7.9 ~ 13.7)	60	5.9 (5.3 ~ 5.9)
Incandescent light 300W	2	20	19.3 (6.1 ~ 19.3)	60	9.2 (5.2 ~ 9.2)
Mercury vapor lamp 175W	5	25	17.4 (6.6 ~ 17.4)	60	8.1 (6.7 ~ 8.1)
Sodium lamp 70W	3	25	19.8 (5.6 ~ 19.8)	60	12.1 (5.0 ~ 12.1)
Flashlight(MX 991/U)	1	25	14.6 (7.9 ~ 14.6)	60	6.7 (4.8 ~ 6.7)
Flashlight (Pelican Stealth Lite 2460)	2	25	26.1 (11.6 ~ 26.1)	60	9.6 (4.6 ~ 9.6)

[Table 4: Distance between the False Alarm Source and the detector]

5.5. Output Signal

- 2 Relay Out(Alarm, Trouble)
- 0~20mA Analog Current Output (stepped)
- RS-485 Modbus

Output Type	Output	Note
Alarm Relay (De-energized)	SPST Default setting N.O	N.O or N.C can be altered Using J2 Jumper
Trouble Relay (Energized)	SPST Default setting N.O	N.O or N.C can be altered Using J3 Jumper
0~20mA Analog Current Output	Source Type	
RS-485	Modbus RTU Protocol	

[Table 5: Output Signal]

- Alarm Relay (De-energized)

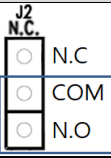
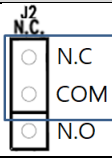
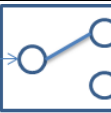
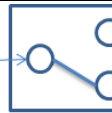
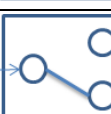
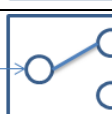
Status		
Relay Jumper		
Normal Status		
Alarm Status		

[Table 6: Alarm Relay Operation and Jumper Alteration]

- Trouble Relay (Energized)

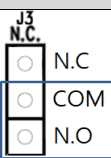
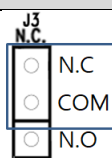
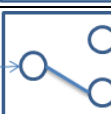
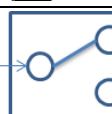
Status		
Relay Jumper		
Normal Status		

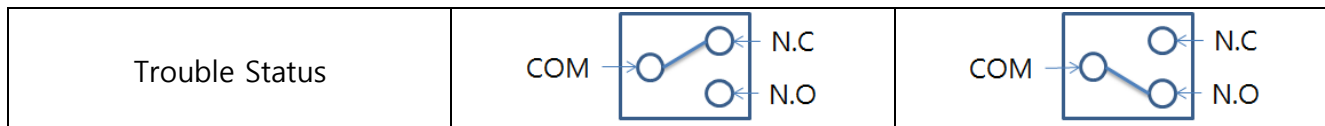

[Table 7: Trouble Relay Operation and Jumper Alteration]

5.6. Detector Status

- Current status of the detector can be identified using the following table:

Status	Description
Warm UP	Conduct tests of each function after energizing
Normal	On fire detection standby after function test is completed
B.I.T.	Self-test function to verify normal operation of each sensor periodically or manually.
Trouble 1 Voltage Variation	This occurs when the input power is out of the operating range (18 ~ 32VDC) for more than 5 seconds and the total number of faults is stored.
Trouble 2 B.I.T. Error	Occurs when the response of the sensor is below the reference value during the operation of the internal self-diagnosis lamp.
Trouble 3 System Error	Occurs when data validation of internal EEPROM fails
Trouble 4 Sensor Error	Occurs when the reference potential of the IR sensor rises or falls and the detection state is maintained for more than one hour.
Pre Alarm	Detection of risk of fire
Fire Alarm	Detection of fire

[Table 8: Detector Status]

- Detector's operation status can be verified from output of each function.

Status	Status LED	Alarm LED	Alarm Relay	Trouble Relay	mA Output
Warm UP	Green, Red Flickers alternately for 500ms	Red Flickers for 500ms	OFF	OFF	4mA±3%
Normal	Green Flickers once in 3s	OFF	OFF	ON	4mA±3%
B.I.T.	Green flickers once in 3s	OFF	OFF	ON	4mA±3%
Trouble 1 Voltage Variation	Yellow Flickers once in 1s	OFF	OFF	OFF	0mA±3%
Trouble 2 B.I.T. Error	Yellow Flickers twice in 1s	OFF	OFF	OFF	1mA±3%

Trouble 3 System Error	Yellow Flickers three times in 1s	OFF	OFF	OFF	2mA±3%
Trouble 4 Sensor Error	Yellow Flickers Four times in 1s	OFF	OFF	OFF	3mA±3%
Pre Alarm	Green Flickers once in 3s	Red flickers for 200ms	OFF	OFF	4mA±3%
Fire Alarm	Green Flickers once in 3s	Red lights on	ON	OFF	20mA±3%

[Table 9: Detector Status Output]

5.7. Latching

- Detection status is maintained during detection of fire.
- All outputs are maintained identical with fire when latching status is maintained.
- B.I.T. is unavailable when latching status is maintained.
- It can only return to Normal status when power is turned OFF and ON again.
- Default setting is Latch ON.

5.8. B.I.T. (Built In Self Test)

- Verifies the normal operation of each sensor.
- Automatically operates once in an hour after Warm UP.
- Can be operated manually using B.I.T. terminal in Terminal PCB. Operates when B.I.T. terminal is connected to N24.
- When error occurs during automatic B.I.T operation, it judges abnormality by rerunning the test 10 times in 5 second interval.
- When operation of sensor or source is abnormal, or when PCB has trouble, self-test error Trouble 2 occurs.

5.9. Trouble Alarm

- Trouble can be identified through four types of output.
- Status LED flickers yellow and fire detection is unavailable until action is taken to resolve the trouble.
- Trouble can be verified through trouble relay, 0~20mA, and RS-485

Trouble	Description	Return Conditions
---------	-------------	-------------------

<p>Trouble 1 Voltage Variation</p>	<p>This occurs when the input power is out of the operating range (18 ~ 32VDC) for more than 5 seconds and the total number of faults is stored.</p>	<p>Automatically returns to normal state when voltage returns to normal range.</p>
<p>Trouble 2 B.I.T. Error</p>	<p>Occurs when the response of the sensor is below the reference value during the operation of the internal self-diagnosis lamp.</p>	<p>Detector inspection needed</p>
<p>Trouble 3 System Error</p>	<p>Occurs when data validation of internal EEPROM fails</p>	<p>Detector inspection needed</p>
<p>Trouble 4 Sensor Error</p>	<p>Occurs when the reference potential of the IR sensor rises or falls and the detection state is maintained for more than one hour.</p>	<p>Detector inspection needed</p>

[Table 10: Trouble Alarm]

5.10. 0~20mA Analog Current Output

- Analog current output following detector status.
- Can be identified using mA terminal on Terminal PCB.

State	Output
Warm Up	4mA±3%
Normal	4mA±3%
B.I.T.	4mA±3%
Voltage Variation (Trouble 1)	0mA±3%
B.I.T Error (Trouble 2)	1mA±3%
System Error (Trouble 3)	2mA±3%
Sensor Error (Trouble 4)	3mA±3%
Pre Alarm	4mA±3%
Fire Alarm	20mA±3%

[Table 11: Analog Current Output]

5.11. RS-485 Address Settings

- RS-485 address can be altered using Dip Switch located on Terminal PCB.
- A maximum of 31 settings can be done using switches no. 1~5.
- Data reception is unavailable upon address overlap.
- When switch is set upwards, it turns ON, otherwise when set downwards, it turns OFF.

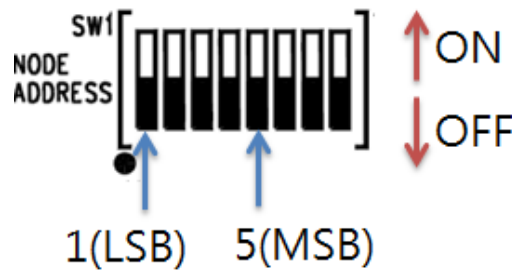

Switch No. / Address	1 (LSB)	2	3	4	5 (MSB)
1 (0x01)	<u>ON</u>	OFF	OFF	OFF	OFF
2 (0x02)	OFF	<u>ON</u>	OFF	OFF	OFF
3 (0x03)	<u>ON</u>	<u>ON</u>	OFF	OFF	OFF
4 (0x04)	<u>ON</u>	OFF	<u>ON</u>	OFF	OFF
5 (0x05)	OFF	<u>ON</u>	<u>ON</u>	OFF	OFF
...

28 (0x1C)	OFF	OFF	<u>ON</u>	<u>ON</u>	<u>ON</u>
29 (0x1D)	<u>ON</u>	OFF	<u>ON</u>	<u>ON</u>	<u>ON</u>
30 (0x1E)	OFF	<u>ON</u>	<u>ON</u>	<u>ON</u>	<u>ON</u>
31 (0x1F)	<u>ON</u>	<u>ON</u>	<u>ON</u>	<u>ON</u>	<u>ON</u>

[Table 12: RS-485 Address]

6. Installation

- Installing the flame detector at site or opening or operating installed flame detector cover should only be performed by approved user or our company's person in charge of installation and repair; failing to do so may cause fire, explosion or other serious personal injury and property damage. Also, please operate only after checking the availability of explosive gas residue or inflammable material around and shutting off the power supply.

6.1. Opening Body Cap

- Use a wrench to open M3 headless bolt that is engaged to body cap.
- Turn the body cap anticlockwise to open.
- When the body cap is opened, terminal block on Terminal PCB will show up.

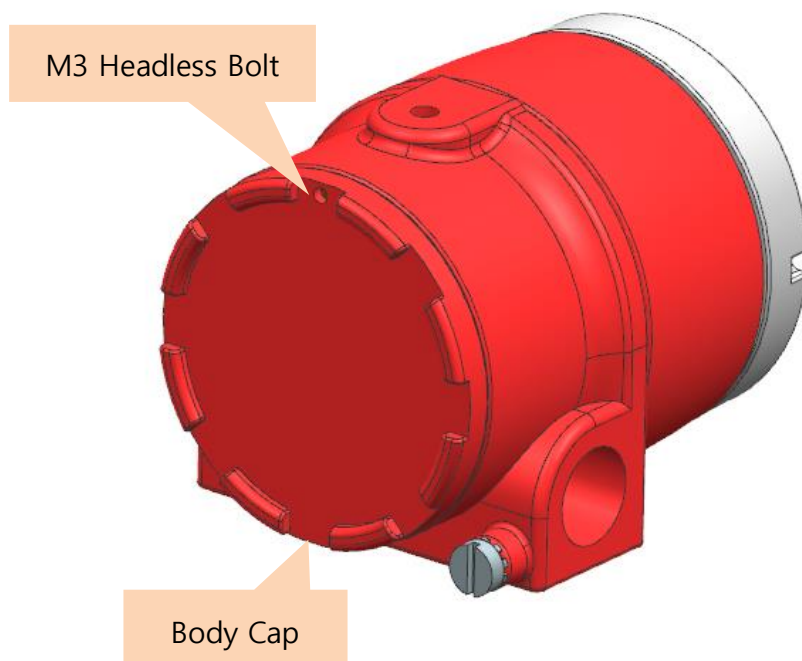

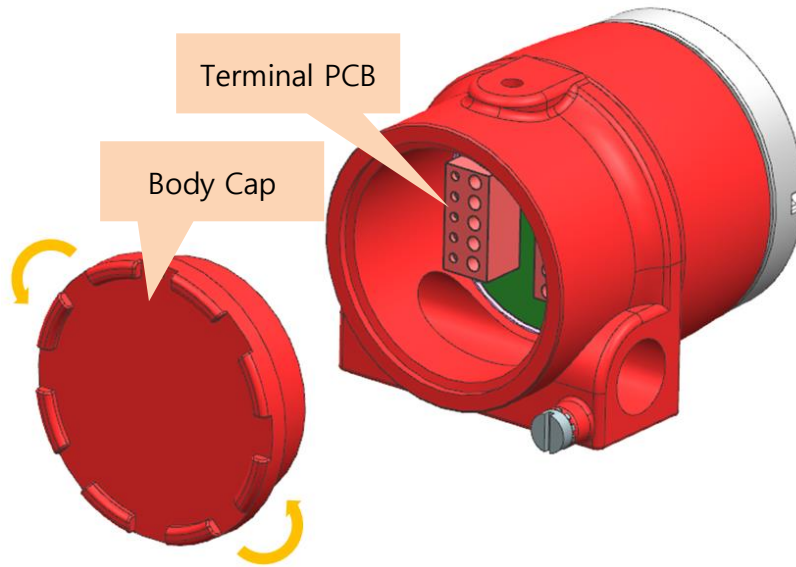

[Figure 3: Opening Body Cap]

6.2. Terminal PCB Configuration

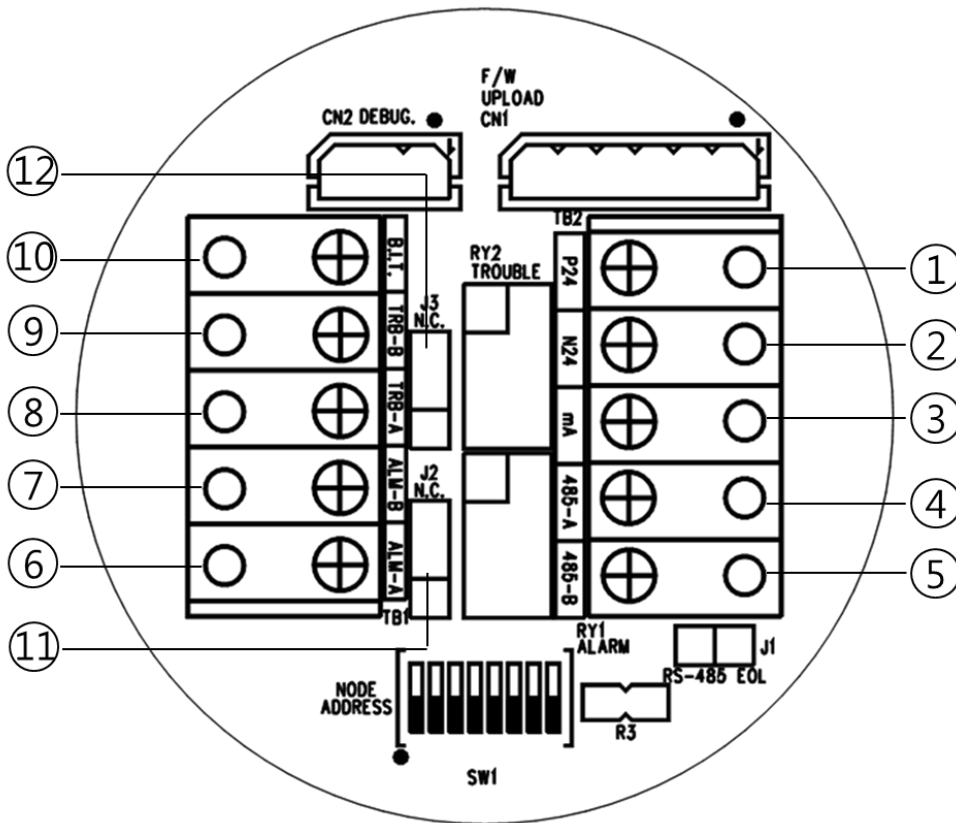

[Figure 4: Terminal PCB Layout]

- Power and signal configuration shall be done using TB1 and TB2 terminals on the Terminal PCB.

No.	Configuration	Descriptions
1	P24	Positive Input
2	N24	Negative Input
3	mA	0-20mA Analog Current Output
4	485-A	RS-485 Positive Signal
5	485-B	RS-485 Negative Signal
6	ALM-A	Alarm Relay Contact Output
7	ALM-B	
8	TRB-A	Trouble Relay Contact Output
9	TRB-B	
10	B.I.T.	Manual Built in Self Test Input (Dry-Contact)

[Table 13: Terminal Configuration]

6.3. Cable Wiring

- Uses 0.75sq * 10C + Shield Cable.
- In order to flawlessly conform with EMC guidelines and protect from interference from RFI and EMI, cables on detector should be shielded and detector should be earthed. Shield should be earthed at the end of detector.

(Use to Only KFI)

No.	Connector No.	Color
1	P24	Red
2	N24	Black
3	mA	White
4	485-A	Yellow
5	485-B	Orange
6	ALM-A	Purple

7	ALM-B	Brown
8	TRB-A	Green
9	TRB-B	Blue
10	B.I.T.	Gray
11	Shield	Black on shrink tube

[Table 14: 0.75sq * 10C + Shield Cable Wiring]

6.4. Length of Installed Cable

- Maximum length between GTF-1100T and power supply is decided by specification of the wire.
- Maximum installation length = $V_{MAXDROP} \div I_{MAX} \div WIRER/m \div 2$
 - ✓ V_{MAX} Drop: Maximum Power Loop Voltage Drop
(=Power Supply voltage – min operating voltage)
 - ✓ I_{MAX} : Maximum current of GTF-1100T
 - ✓ $WIRER/m$: The resistance of the wire (ohms/meter value available in wire manufacturer’s specification data sheet),
- For example, installation length when using power supply 16AWG is as below:
 - ✓ GTF-1100T minimum operating voltage = 18 V dc
 - ✓ $V_{MAXDROP} = 24 - 18 = 6V$
 - ✓ $I_{MAX} = 0.122A$
 - ✓ $6 \div 0.122 \div 0.01318 \div 2 = 1865.718m \approx 1866m$

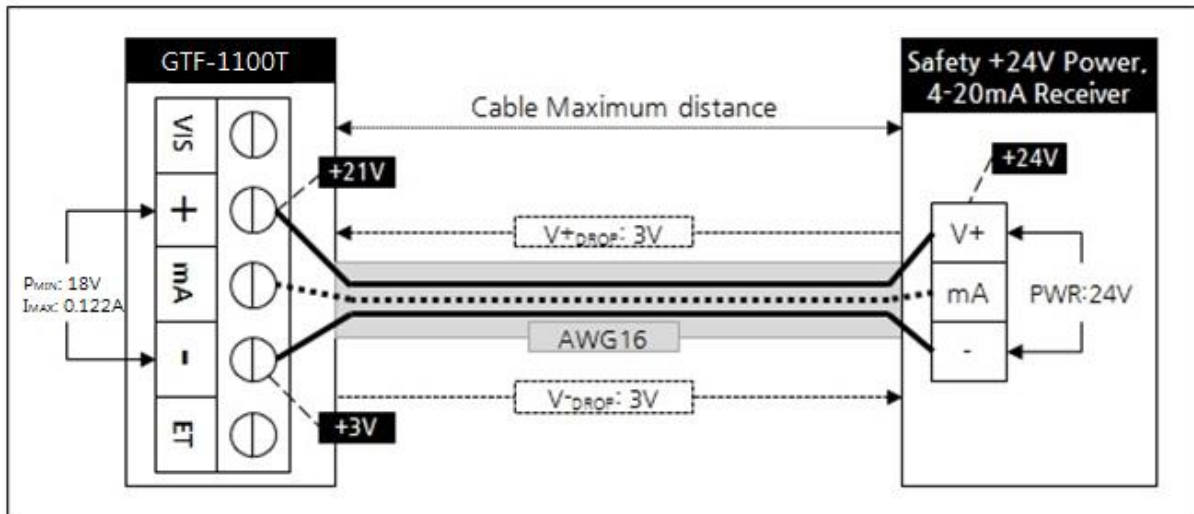

[Figure 5: Calculation of Length of GTF-1100T Cable Installation]

- Cable installation lengths according to classification of cable are as below:

AWG	mm ²	Copper resistance(ohms/m)	Meters
12	3.31	0.00521	4720
14	2.08	0.00828	2970
16	1.31	0.01318	1865
18	0.82	0.02095	1174
20	0.518	0.0333	739

[Table 15: Length According to Classification of GTF-1100T Cable]

6.5. Wiring

- Wiring methods to connect connector of the Terminal PCB and external equipment:

6.5.1. Relay Wiring

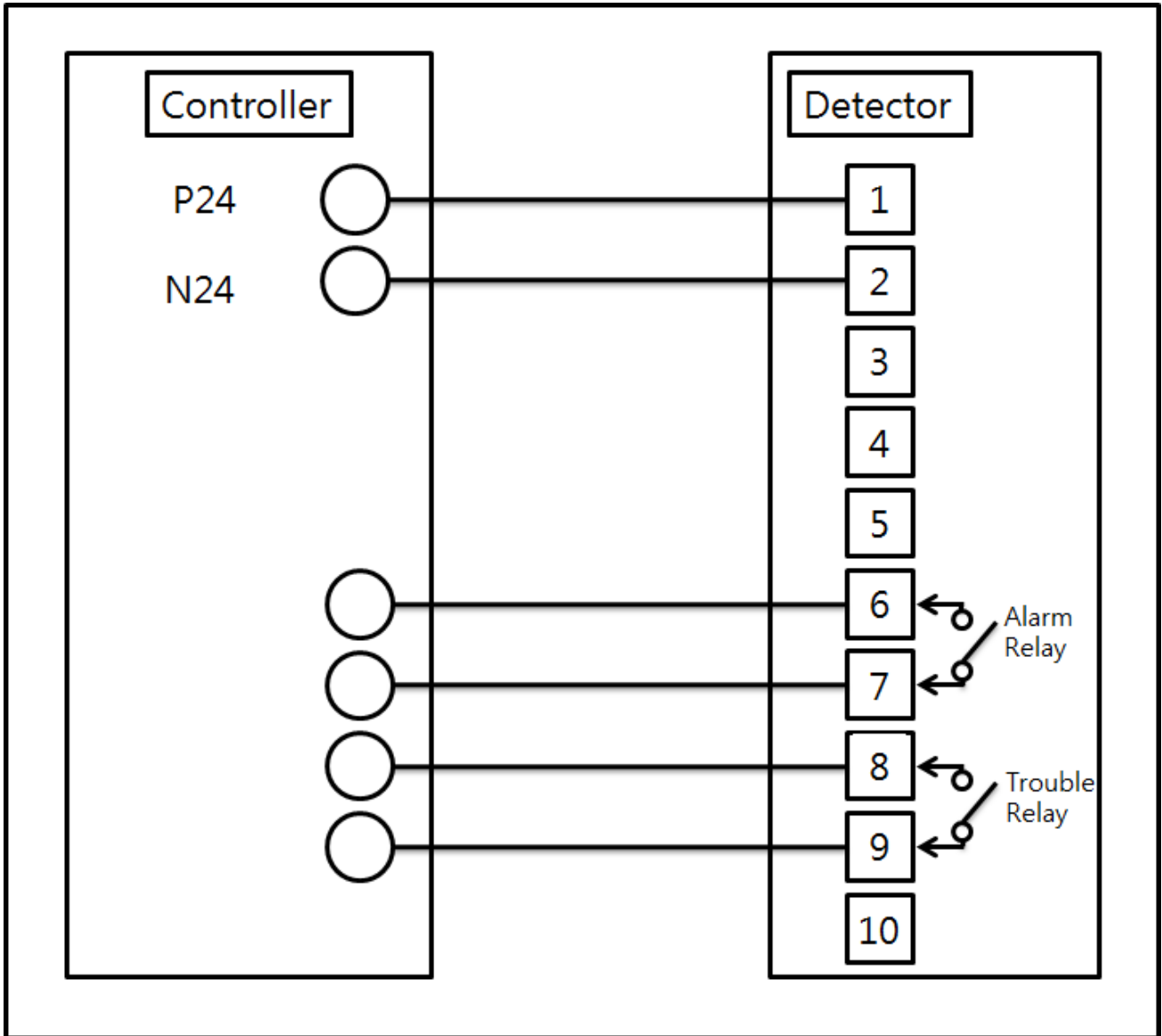

[Figure 6: Configuration of Relay Cable]

6.5.2. Configuration of Analog Output Cable

- 0~20mA analog output can be configured with Sink Type configuration.

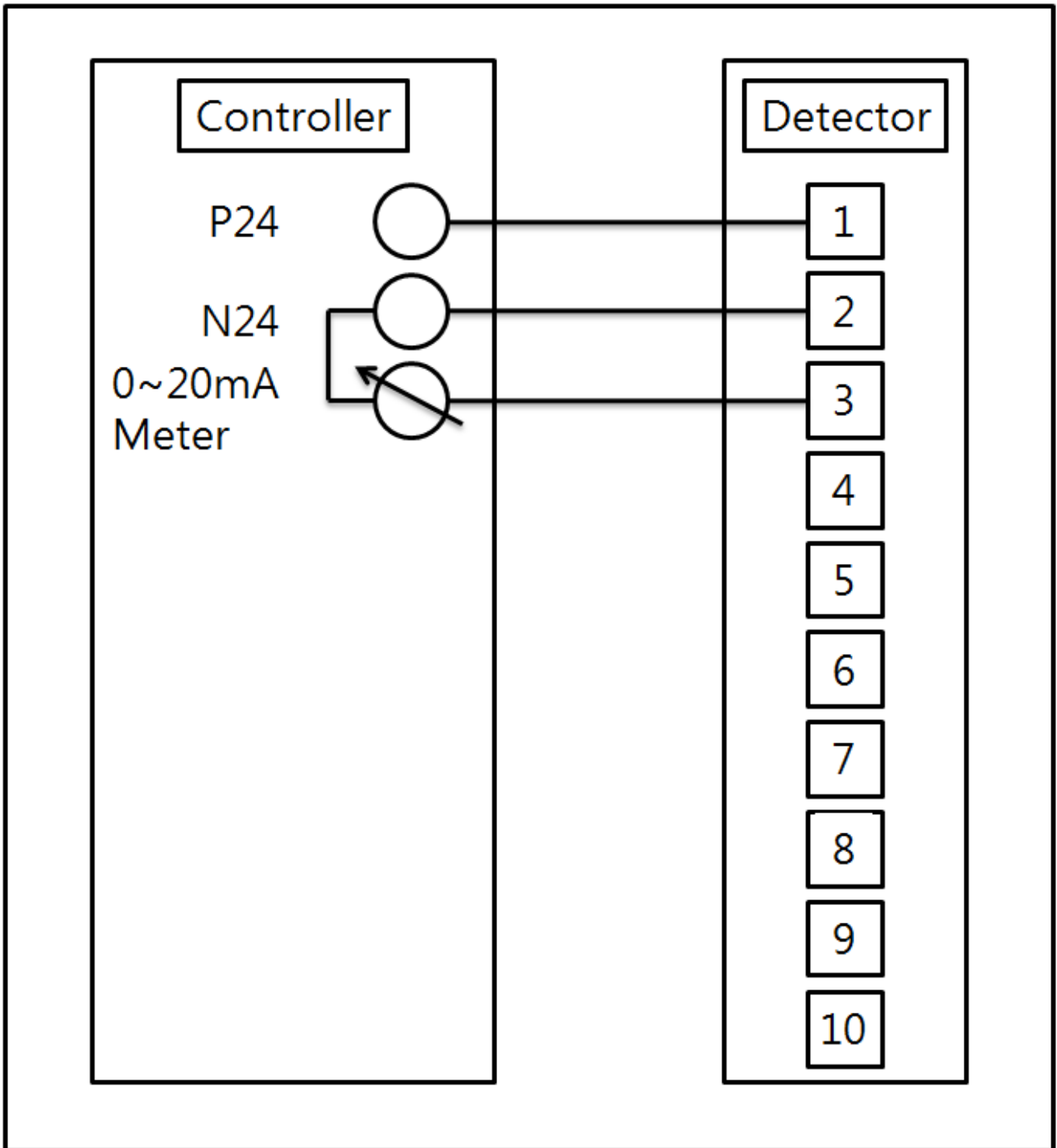

[Figure 7: Configuration of Analog Output Cable]

6.5.3. Configuration of RS-485 Cable

- In case of RS-485, multiple configurations are possible.
- Up to 31 connections can be configured with no overlapping detector's RS-485 address.

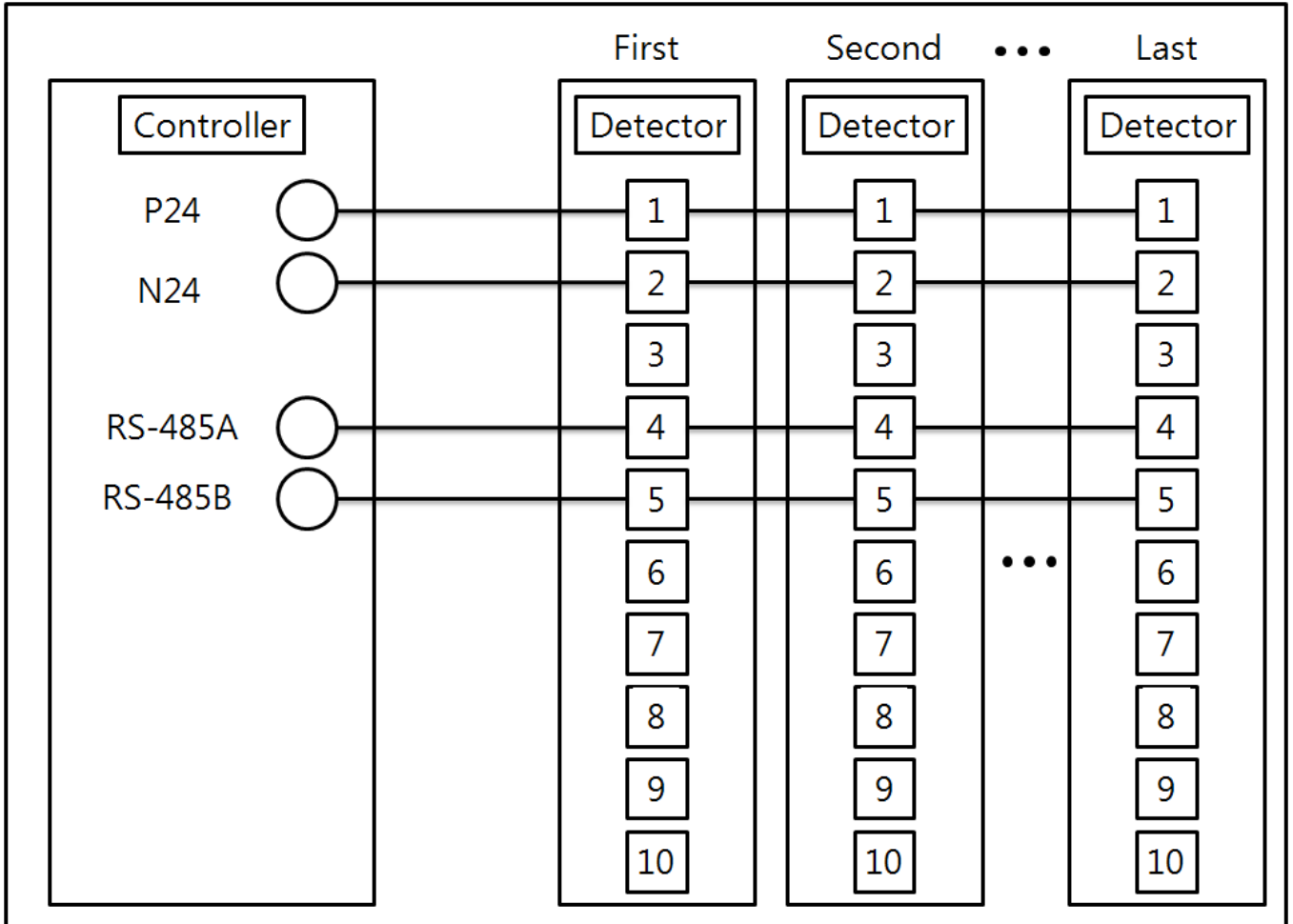

[Figure 8: Configuration of RS-485 Cable]

6.6. Blanking Cable Entry

- Use the appropriate explosion protection type blanking plug or supplied blanking plug to close any unused entries

7. Names and Description of Parts

7.1. Front Configuration

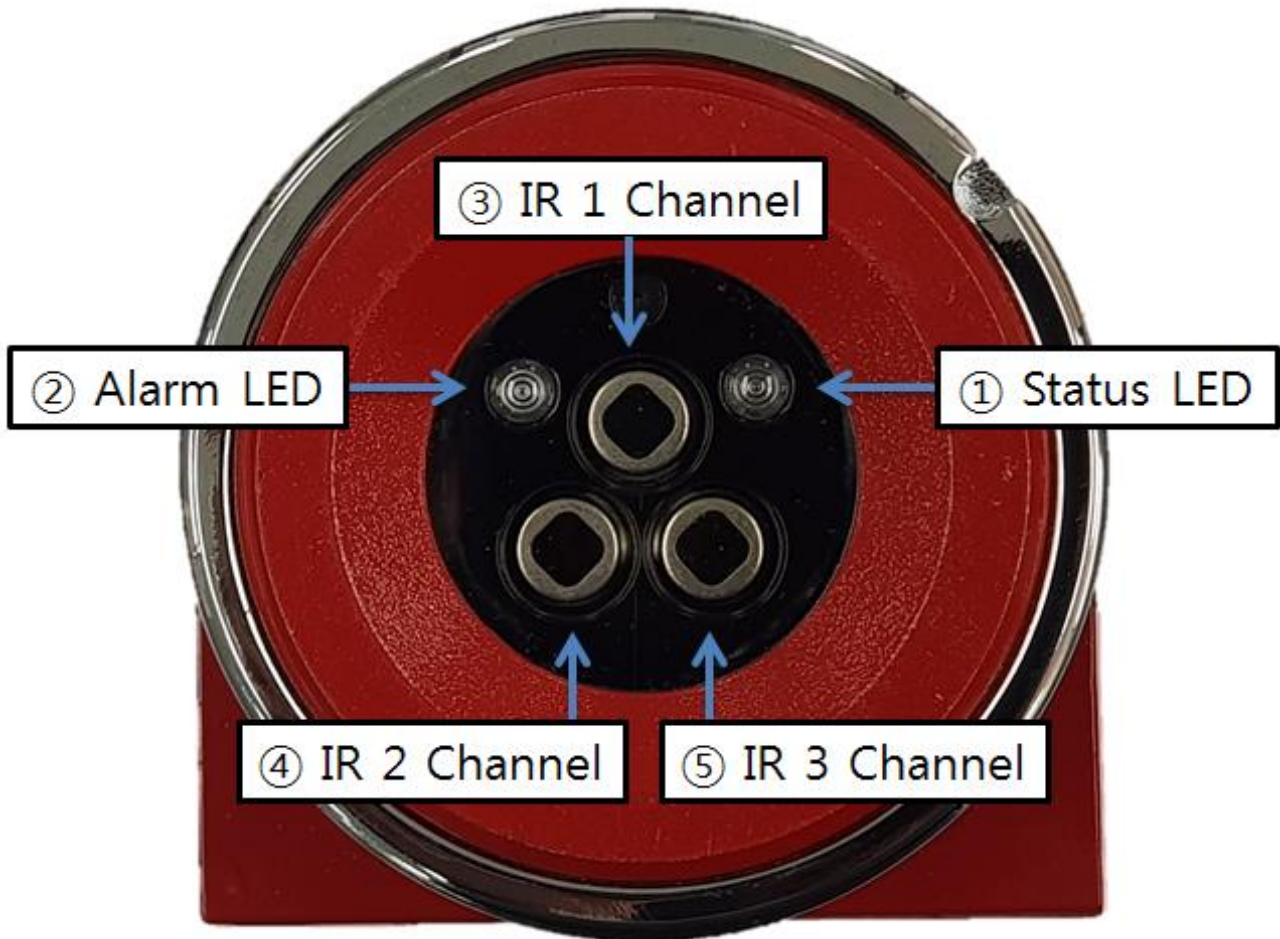

[Figure 9: Front Configuration]

No	Name	Descriptions
1	Status LED	Green flickers when Normal Yellow flickers when Trouble
2	Alarm LED	Lights up during fire
3	IR 1 Channel	Sensor that detects wavelengths of 4.5~4.8 μm
4	IR 2 Channel	Sensors that detect wavelengths other than CO2
5	IR 3 Channel	Sensors that detect wavelengths other than CO2

[Table 16: Front Configuration]

7.2. Parts

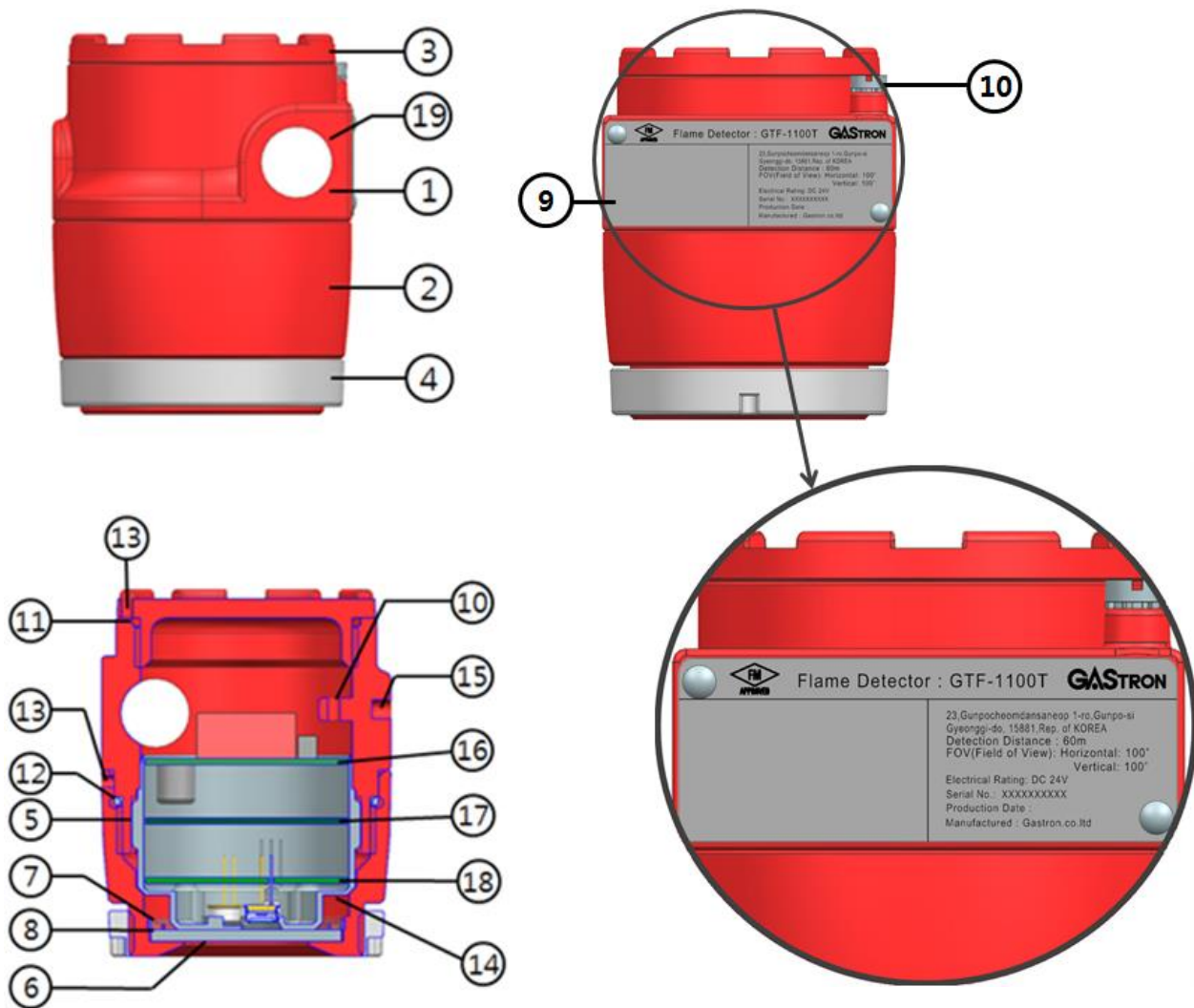

***WARNING – DO NOT OPEN WHEN ENERGIZED.**

[Figure 10: Parts of GTF-1100T]

No	Name	Descriptions
1	Case body	Protects sensors and PCB board installed in the housing from external environment changes and impact.
2	Case cover	Put together with detector housing body, protects PCB board installed in the interior from external environment changes and impact.
3	Body cap	Protects PCB board install in the housing from external environment changes and impact.
4	Cover ring	A ring that fixes cover to bracket so that engaging front can be easy, or able to install weather proof cover.
5	PCB cover	Protects sensors and PCB board from external environment and impact while assembling, and it is easy to attach and detach.
6	Glass Sapphire	Transmission part which protects sensors included in the housing from external environmental changes and impact.
7	Glass ring	A fix ring that fixes glass.
8	Gasket	Prevents damage of glass and acts as waterproofing so that rain may not permeate.
9	Cert. label	Shows the product's name of model, certifications, serial number, warning and etc. (Warning – Do not open when electric current is applied.)
10	Internal / External Ground	Interior/Exterior of the detector needs to be grounded to protect from external noise or strong electric system. (Ground terminal: JOT4-6, Ground cable $\geq 4 \text{ mm}^2$)
11	O-RING(AN138)	Acts as waterproofing so that rain may not permeate.
12	O-RING(S56)	Acts as waterproofing so that rain may not permeate.
13	SETHSC-M3-3-S4	A set screw to prevent opening of cover from detector housing body.
14	SCRH-M3-6-NiP	A set screw to separate PCB and PCB protection cover.
15	Mount Bracket tap	A bracket installation tap to fix detector on external wall or other mount hole.
16	TERMINAL PCB	Comprises of connector that can connect with external devices and dip switch which sets RS-485 address.
17	MAIN PCB	Calculates input signals from sensors to detect fire and control each output signal.
18	SENSOR PCB	Comprises of sensors for fire detection, source for self-test, and Status LED and Alarm LED that are used to identify status of detector.
19	Electrical Connection	A connector to engage cable grand.

[Table 17: Descriptions of Parts]

8. Dimensions

8.1. GTF-1100T Dimensions

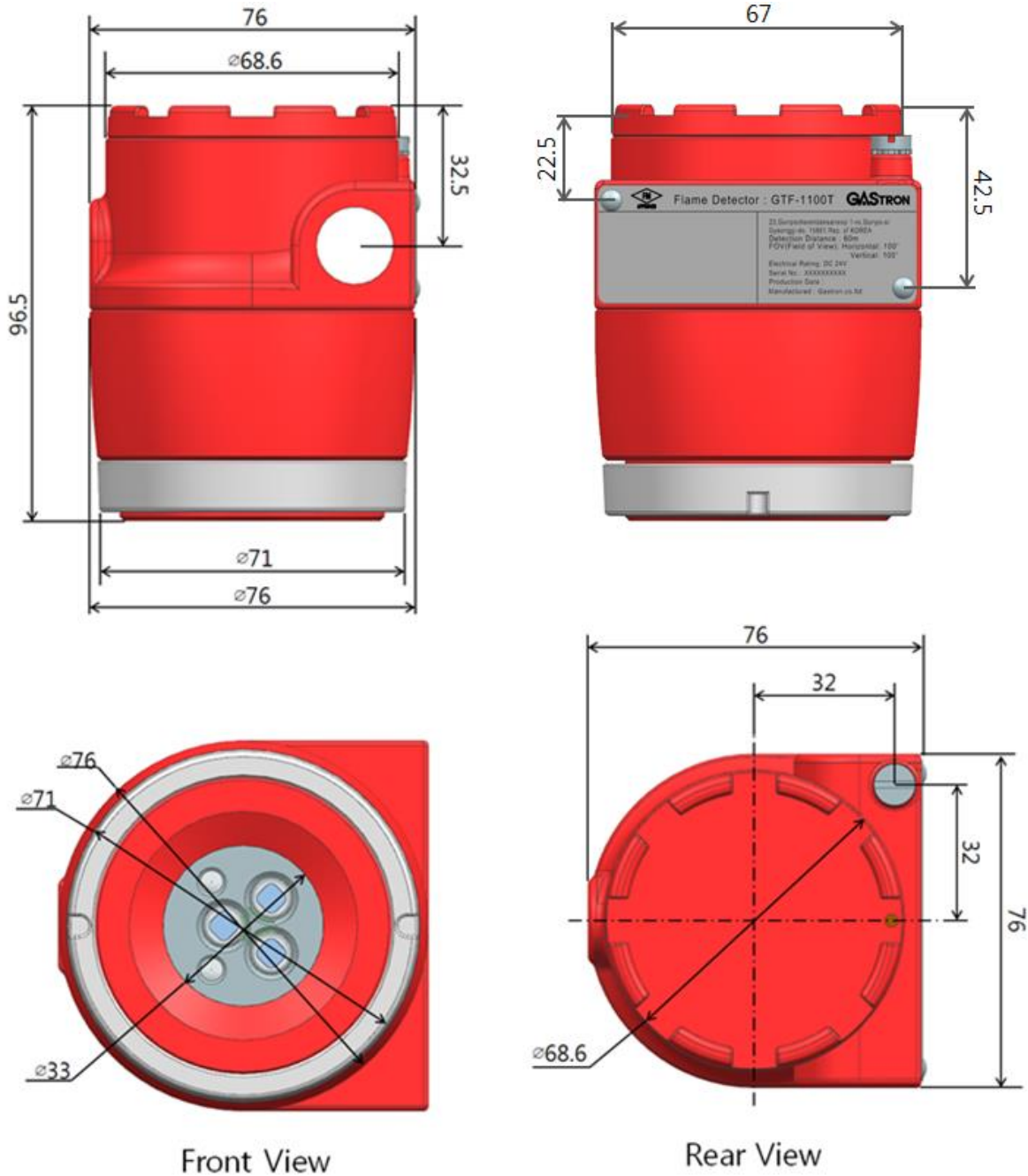

[Figure 11: GTF-1100T Dimensions]

8.2. GTF-1100T + Weather Proof Cover + Bracket Assembly Dimensions

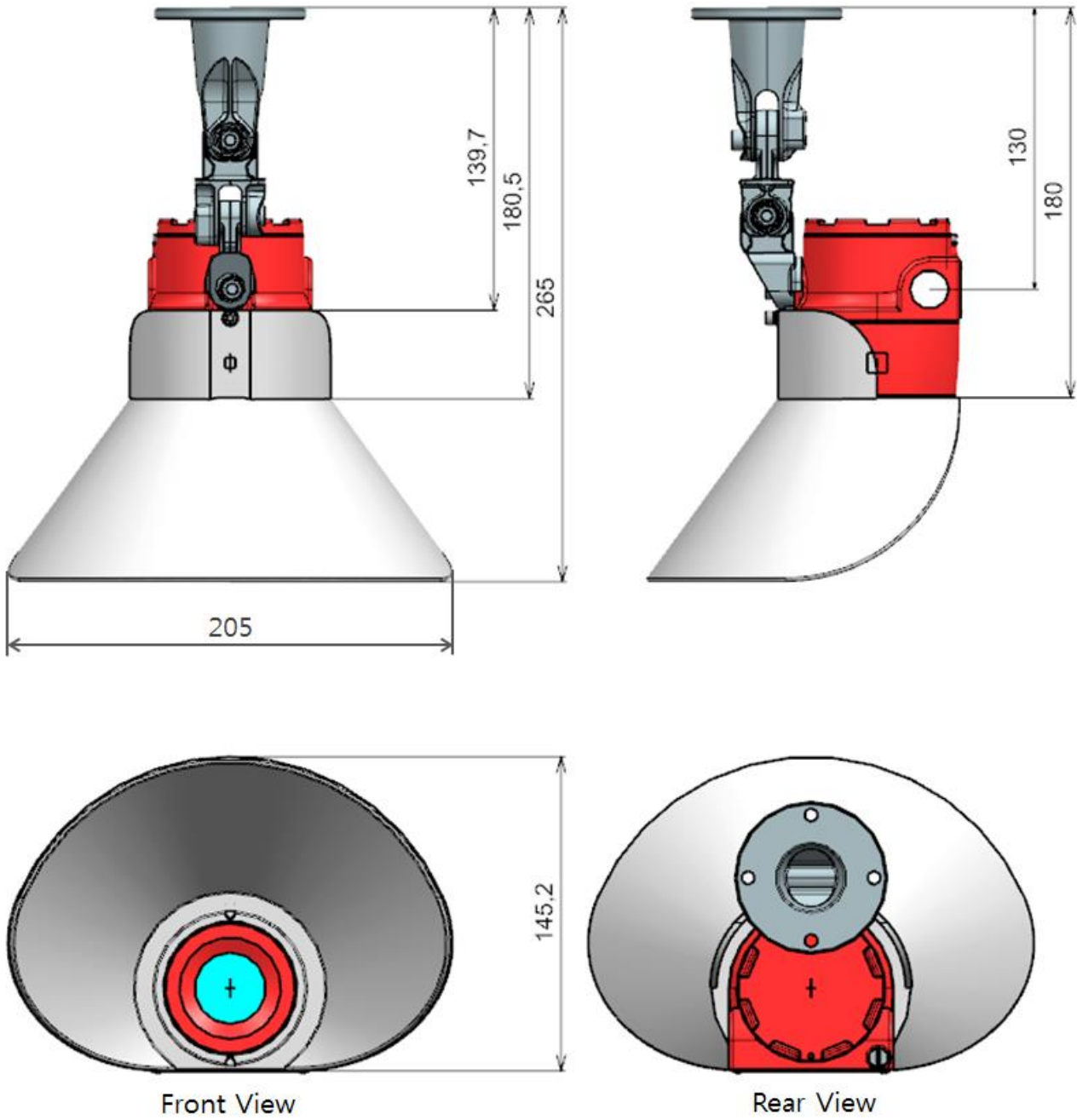

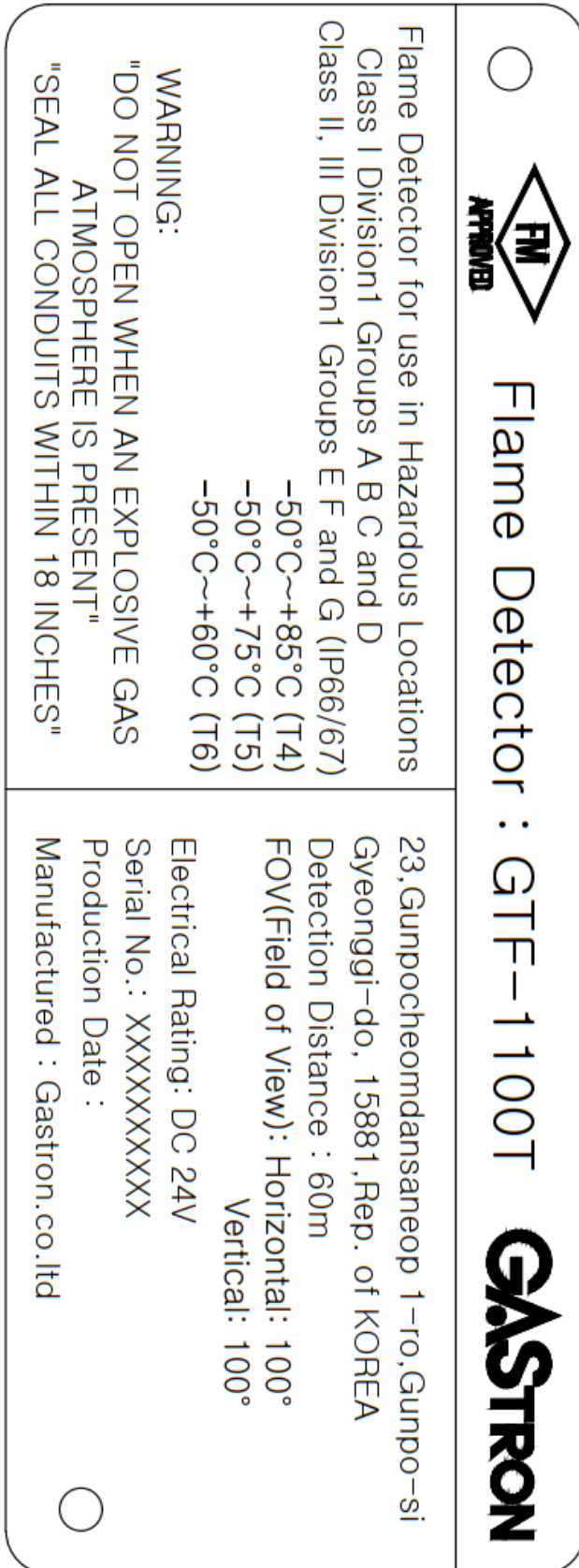

[Figure 12: GTF-1100T + Weather Proof Cover + Bracket Assembly Dimensions]

8.1. GTF-1100T Certification Label (Approval to FM)



[Figure 13: Certification Label (Approval to FM)]

8.2. GTF-1100T Certification Label (Approval to ATEX/IECEX/NEPSI)

<p style="text-align: center;">○</p> <p style="text-align: center;">  0344  II 2 G  GYJ19.1199X </p> <p style="text-align: center;">Flame Detector : GTF-1100T</p> <p style="text-align: center;">GASTRON</p>	<p>23, Gunpocheomdansaneop 1-ro, Gunpo-si Gyeonggi-do, 15881, Rep. of KOREA</p> <p>Detection Distance : 60m</p> <p>FOV(Field of View): Horizontal: 100° Vertical: 100°</p> <p>Electrical Rating: DC 24V</p> <p>Serial No. : Production Date : Manufactured : Gastron.Co.Ltd</p> <p style="text-align: center;">○</p>
<p>ELECTRICAL RATING: 24 VDC/MAX 96mA IECEX BAS 19.0068X Ex db IIC T* Gb (Ta -40°C to +**°C) Ex tb IIIC T80°C Db (Ta -40°C to +60°C) Baseefa 19ATEX0080X II 2G Ex db IIC T* Gb (Ta -40°C to +**°C) II 2D Ex tb IIIC T80°C Db (Ta -40°C to +60°C) (*), (**) – Refer to table in schedule</p> <p>WARNING: *DO NOT OPEN WHEN AN EXPLOSIVE ATMOSPHERE IS PRESENT *THE MAXIMUM WORKING TEMPERATURE OF THE CABLE FOR FIELD WIRING SHALL BE NO LESS THAN 110°C * **SEE IDENTIFICATION OF THE THREAD OF THE CABLE ENTRY HOLES ON THE INSTRUCTION MANUAL.**</p>	

[Figure 14: Certification Label (Approval to ATEX/IECEX/NEPSI)]

9. Operation

- *In order to prevent detector's normal operation or damage, please energize after checking on wiring condition.*

9.1. Energizing

- Energize after checking on wiring condition.
- When energized, Status LED and Alarm LED will flicker alternately and start Warm UP.
- While Warm Up is being progressed, verify operation by executing internal system check and B.I.T.
- When check is done, Status LED flickers green and the device goes into standby in Normal state.
- While abnormal operation occurs during Warm Up, Trouble Alarm occurs after Warm Up is done.

9.2. Default Function Settings

- The following are default values configured in detector.

Function	Configured Value	Note
Auto B.I.T	ON	
Latch	ON	
RS-485 Address	1	Can be altered according to site situations.
Alarm Relay (De-Energized)	N.O	Can be altered by request or by consumer.
Trouble Relay (Energized)	N.O	Can be altered by request or by consumer.

[Table 18: Default Function Settings]

9.3. Auto B.I.T

- Executes periodic self-test after Warm Up.
- No changes to detector during self-test.
- When completed normally, device executes fire detection standby in normal status.
- When problem occurs during self-test, self-test repeats every 5 seconds.

- When problem occurs for total of 10 times, Trouble 2 occurs and additional actions are needed.
- When fire occurs and latch turns ON, device does not execute self-test.
- Manual self-test can be executed using B.I.T terminal on Terminal PCB.

9.4. Test using FS-320 Simulator

- As the test using real fire in explosion-proof or hazard area was not available, replacement test using simulator was executed.
- Fire was detected from a source that creates spectrum similar with real fire by installed detector.
- As detector’s each function during simulator test had identical output with real fire, connections with alarm or each fire extinguishing system and external devices were shorted during execution of simulator test.
- Please refer to the Accessories Page.

10. Approvals

10.1. CE

- Test Standard(method) Used: EN 50130-4:2011, EN61000-6-4:2007 + A1:2011
- Emission Test Regulation / Standards

Applied Standard	Title
EN 61000-6-4:2007 + A1:2011	Radiated Electric Filed Emissions

[Table 19: Emission Test Regulation / Standards]

- Immunity Test Regulations / Standards

Applied Standard	Title
EN 50130-4:2011	
EN 61000-4-2:2009	Electrostatic Discharge
EN 61000-4-3:2006 + A1:2008 + A2:2010	Radiated Electric Filed Emissions
EN 61000-4-4:2012	Electrical Fast Transients / Bursts
EN 61000-4-5:2014	Surge Transients

EN 61000-4-6:2014	Conducted Disturbance
-------------------	-----------------------

[Table 20: Immunity Test Regulations / Standards]

10.2. FM

- Approvals Classification
 - Class I Division1 Groups A B C and D
 - Class II, III Division1 Groups E F and G
 - IP 66, 67
- Explosion Proof type
 - Explosion Proof Enclosure

10.3. ATEX/ IECEx/ NEPSI

- Approvals Classification
 - Ex db IIC T6...T4 Gb
 - Ex tb IIIC T80°C Db IP66/67
- Explosion Proof type
 - Explosion Proof Enclosure

11. Accessories

※ *Below accessories are not for ATEX/IECEX/NEPSI explosion protection*

11.1. Flame Simulator (Part No. FS-320)

11.1.1. Overview

GTF-320 is a test simulator to identify GTF-1100T's normal operation in explosion-proof or hazard area with the detector installed. This was produced to execute virtual fire test as test with real fire was unavailable.

FS-320 was from the source and IR using discrete flicker to create a spectrum similar with fire so that GTF-1100T could recognize it as fire.

This was created as a case with Aluminum alloy material and explosion proof construction, and its lightweight enables this to be portable. This can be used 100 times when fully charged with proprietary charger. Low power design enables this to be carried for a long time.

11.1.2. Features

- An exclusive simulator to test GTF-1100T.
- Power source comes from the battery which enables GTF-320 to be portable.
- About 100 uses per full charge.
- Low power design enables GTF-320 to be carried for a long time.
- Explosion-proof construction enables usage in explosion proof or hazard area.

11.1.3. Operation

- Place FS-320 to face detector's front.
- Pressing the handle's operation switch will start function test such as internal temperature check and battery check.
- When function check is finished normally, the LED in operation switch lights green and the source installed internally operates aperiodically for 30 seconds.
- When trouble occurs during function check, it is expressed by color of the LED in the operation switch.
- Maintain until detector recognizes the operation as fire.
- Pressing operation switch again during operation or passing 30 seconds will automatically put FS-320 in standby.
- When detector does not recognize a fire, repeat the process 2~3 times to verify.
- In case of detector not recognizing a fire after the repeated process, a detector inspection is needed.
 - Check for foreign object on sapphire glass at the front of detector
 - Sensor checks through B.I.T

11.1.4. Trouble Indication

- LED lights up according to each trouble and turns OFF after 3 seconds.

Trouble	LED Color
Battery Low Voltage	Red ON
Internal Temperature Rises	Red flickers for 500ms

[Table 21: Trouble Indication]

11.1.5. General Specifications

I T E M S	S P E C I F I C A T I O N
Detection Distance	5m
Indicator	Status LED (2 Color)
Approvals Classification	KCs: <u>Ex dII B</u> T4, T5, T6
Warranty	2Year

11.1.6. Mechanical Specifications

I T E M S	S P E C I F I C A T I O N
Explosion Proof type	Explosion Proof enclosure
Dimension	148(W) ×164(H) ×303(D) mm
Weight including Sensor	App. 0.7kg
Material	Aluminum alloy

11.1.7. Electrical Specifications (Standard Type)

I T E M S	S P E C I F I C A T I O N
Battery	14.8V (3.7V 4cell Ni-Ion Battery)
Current	2.8A
EMC Protection	EN 61000-6-3

11.1.8. Environmental Specifications

I T E M S	S P E C I F I C A T I O N
Storage Temperature	-20°C ~ 60°C
Operation Temperature	-20°C ~ 50°C
Operation Humidity	Up to 95% RH (Non-condensing)

11.1.9. Charger Specifications

I T E M S	S P E C I F I C A T I O N
Charger Input	AC 100~240V / 50~60Hz / 1.0A
Charger Output	16.8V / 2.5A
Charger Indicator	Bi-Color LED Indicator (RED & GREEN)
Fully Charge Time	App. 2 Hours

[Table 22: FS-320 Specifications]

11.1.10. Names of Parts

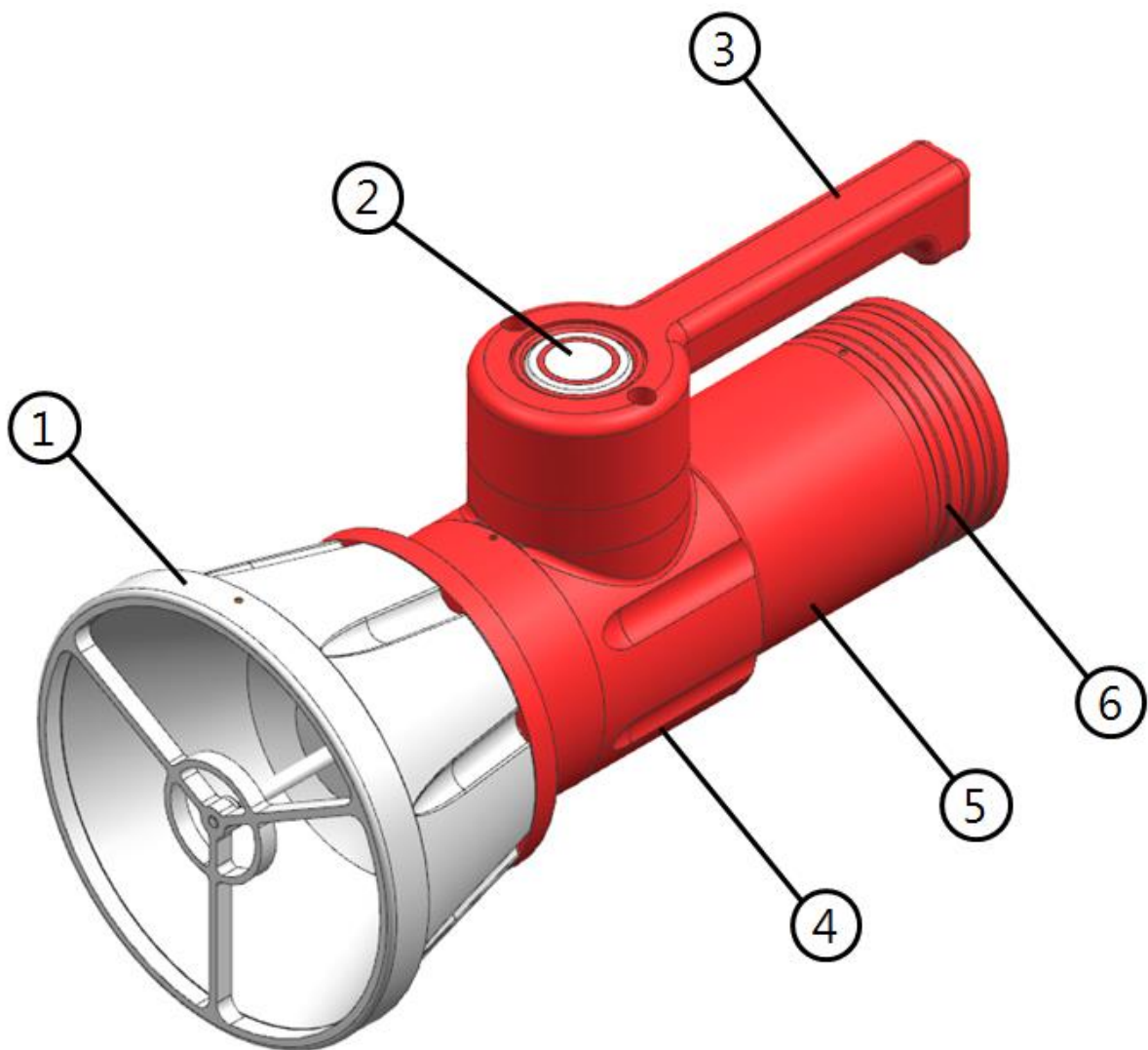

[Figure 15: Names of FS-320 Parts]

No	Name	Descriptions
1	Reflector Assembly	Reflector enabling light from lamp to be shone up to far distance.
2	Push Button	Turns the power of FS-320 on and off, informs the status by lighting up the LED.
3	Handle	Handle that is designed for easy carriage of FS-320
4	Top Cover	Part that engages to body to protect main board.
5	Body	Part that protects main board and battery pack.
6	Back Cover	Back cover part that protects charger jack which connects to battery pack.

[Table 23: Descriptions of FS-320 Components]

11.1.11. Charging the Battery

- Avoid following areas during charging:
 - Explosion-proof or hazard area
 - Inside hot vehicle (above 40°C)
 - Humid or wet area
- Separate the simulator’s back cover.
- Connect charger to the simulator’s DC jack.
- Only the charger supplied together with FS-320 should be used.
- Charging progress can be identified from LED in charger:
 - Red light: Charging
 - Green light: Charging complete
 - Red flicker: Trouble during charging (Faulty battery or charger).
- The simulator will not operate when operation switch is pressed during charging.
- When charging is complete, remove the charger from the simulator and safe keep.

11.1.12. EMC

Applied Standard	Title
EN 61000-6-3	Radiated Emission

[Table 24: Emission Test Regulation / Standards]

Applied Standard	Title
EN 61000-4-2:2009	Electrostatic Discharge
EN 61000-4-3:2006 + A1:2008 + A2:2010	Radiated Electric Field Emissions
EN 61000-4-6:2014	Conducted Disturbance

[Table 25: Immunity Test Regulations / Standards]

11.2. Weather Proof Cover (Part No. FWP-1000)

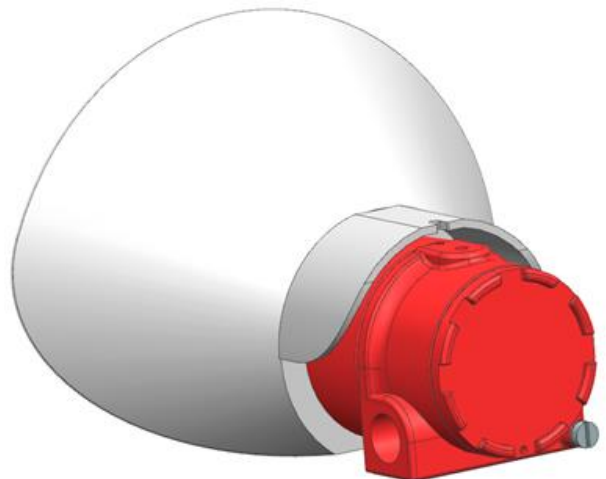
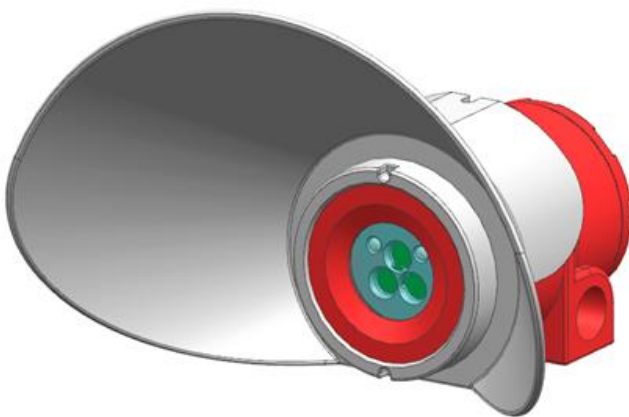
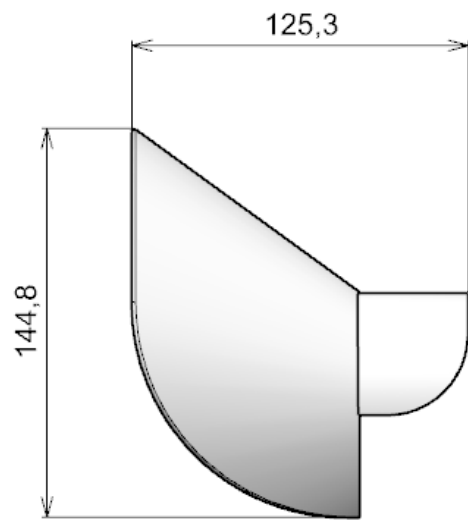
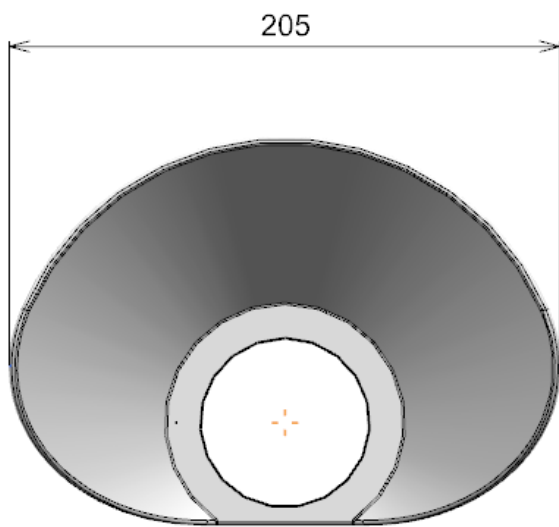
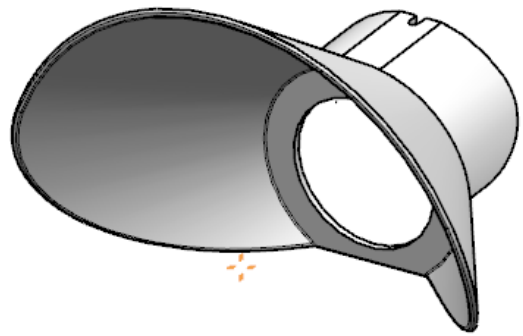
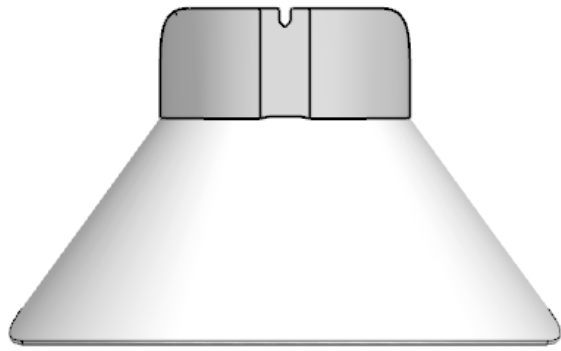

[Figure 16: Weather Proof Cover]

11.3. Weather Proof Cover Assembly

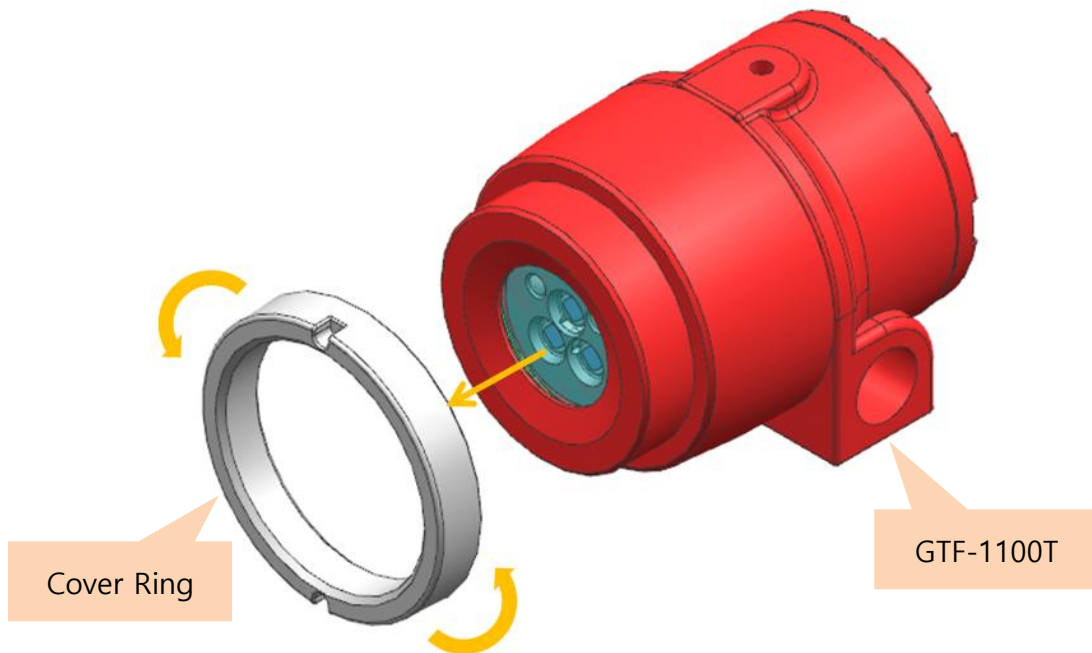

1. Remove cover ring from GTF-1100T by turning as shown in the diagram.

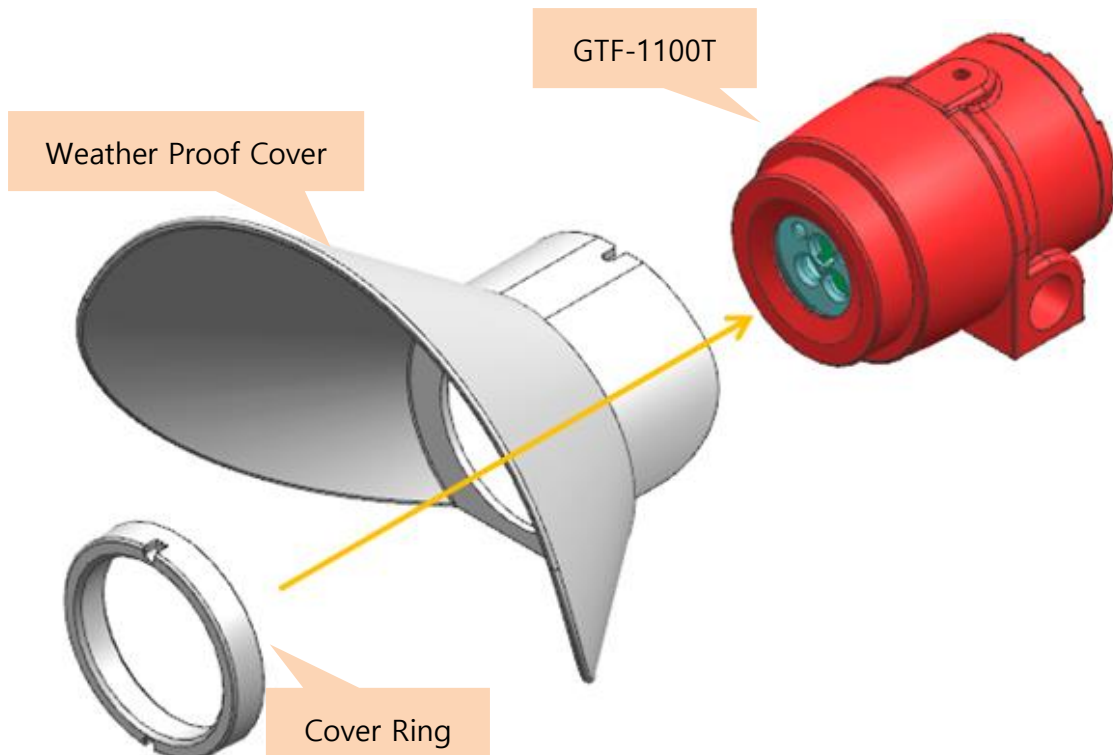

[Figure 17: Weather Proof Cover Assembly]

2. Attach Weather Proof Cover to GTF-1100U first, then tighten cover ring.

11.4. Mounting Bracket Dimension (Part No. FMB-1000)

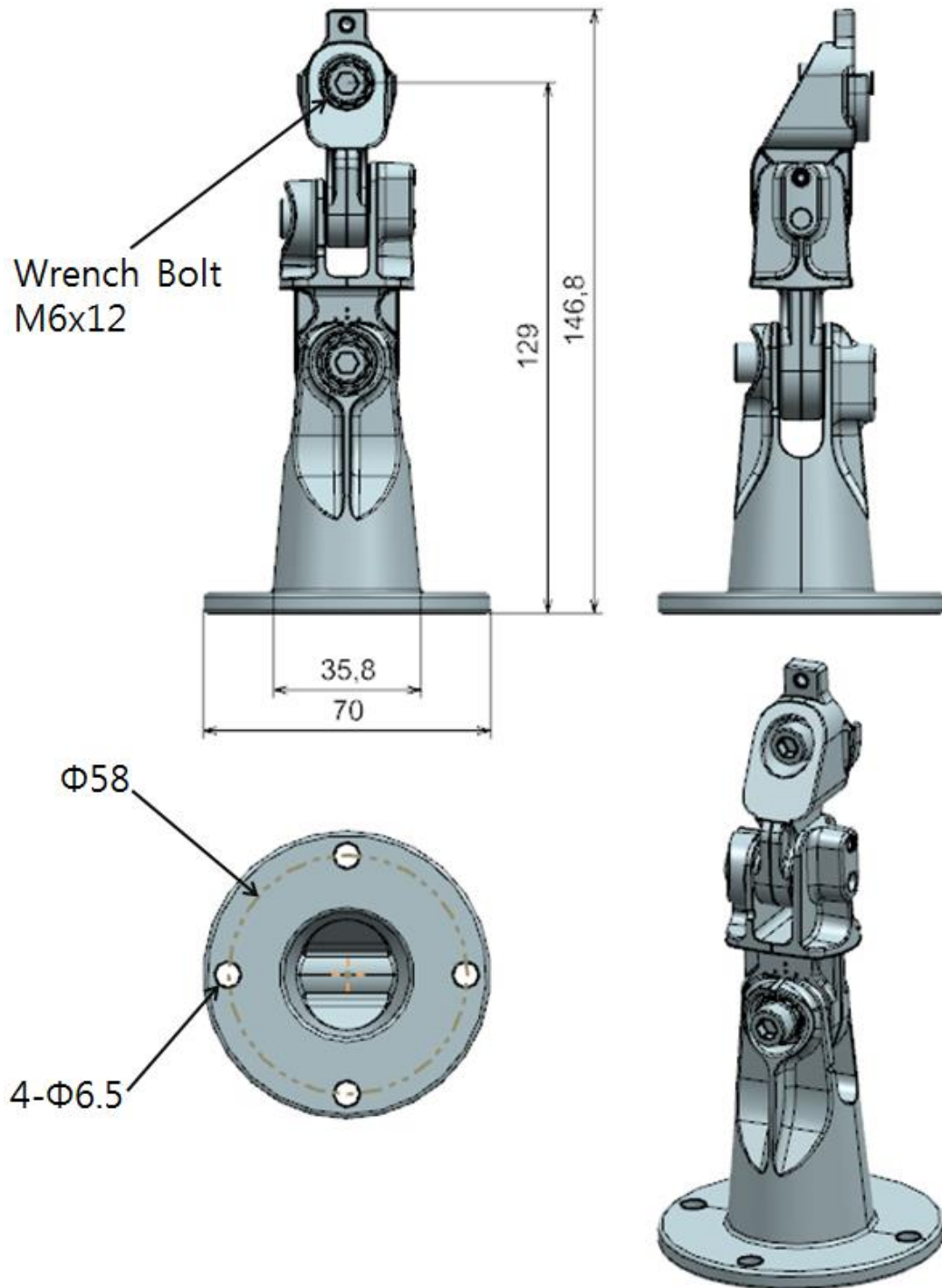

[Figure 18: Bracket Dimension]

11.5. Bracket Assembly

- Assemble using M6x12L bolts with bracket hole and Mount tap on GTF-1100T as shown in the diagram.

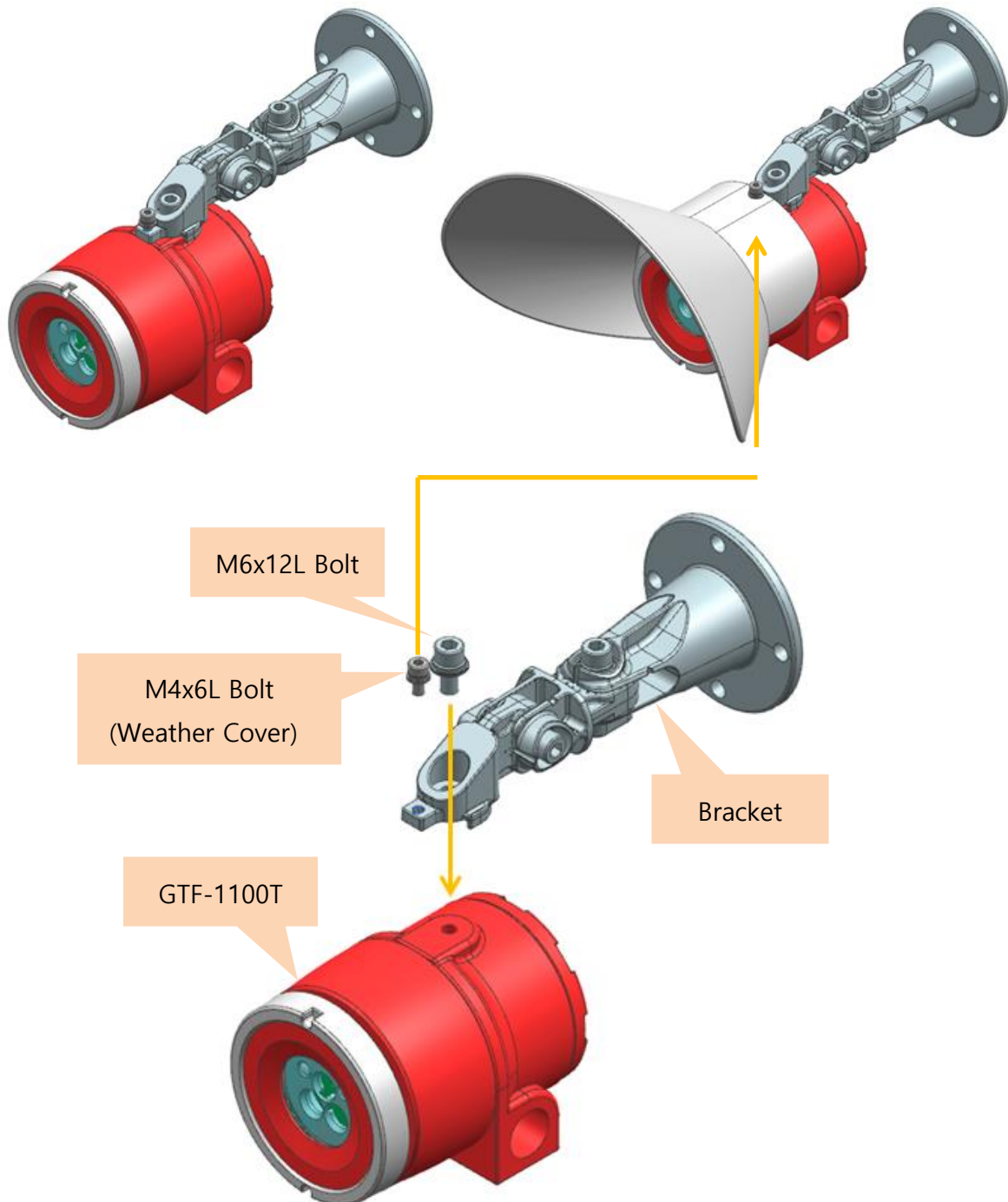

[Figure 19: Bracket Assembly]

11.6. Bracket Tilt

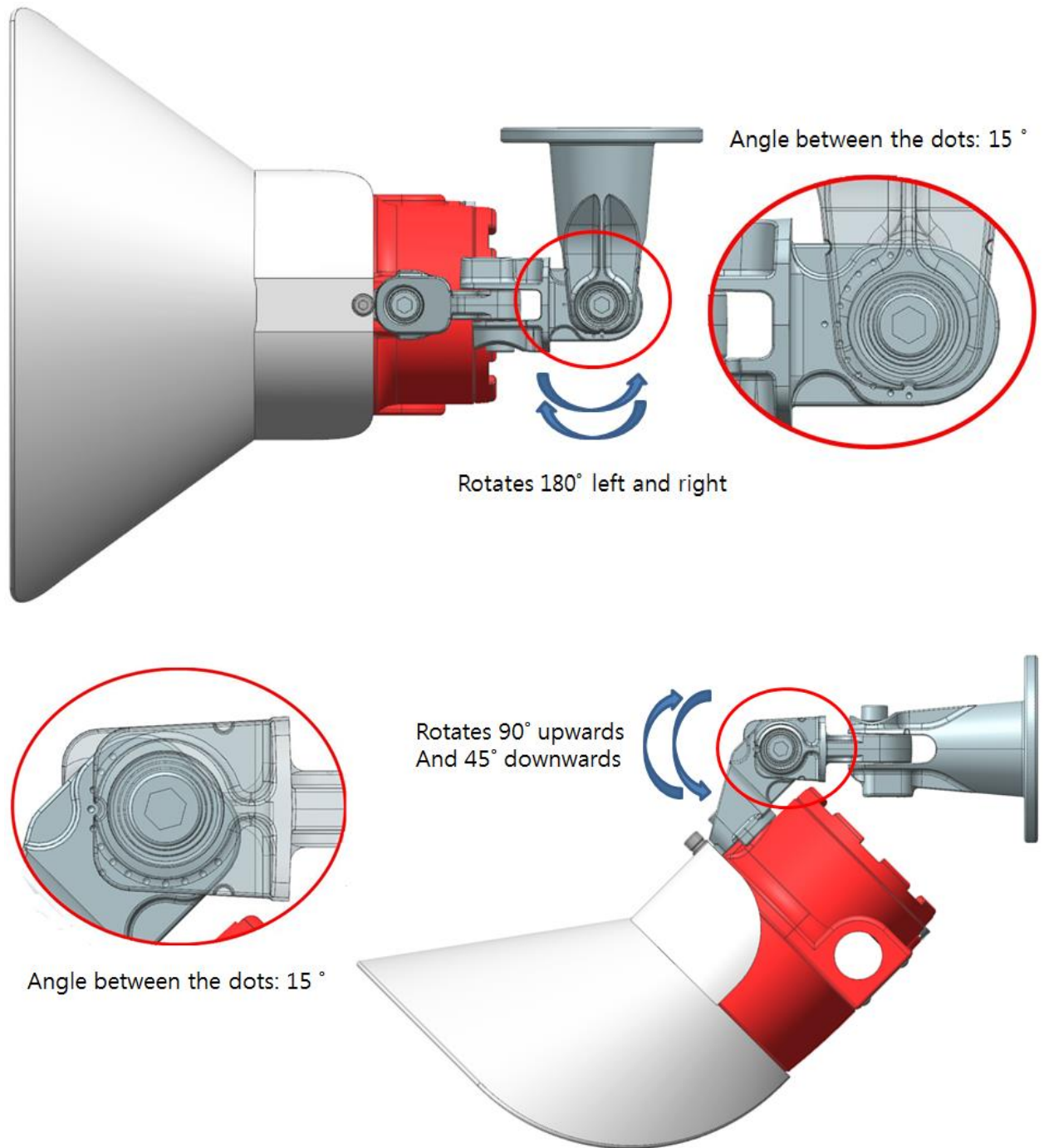

[Figure 20: Bracket Tilt]

11.7. Cable Grand Direction

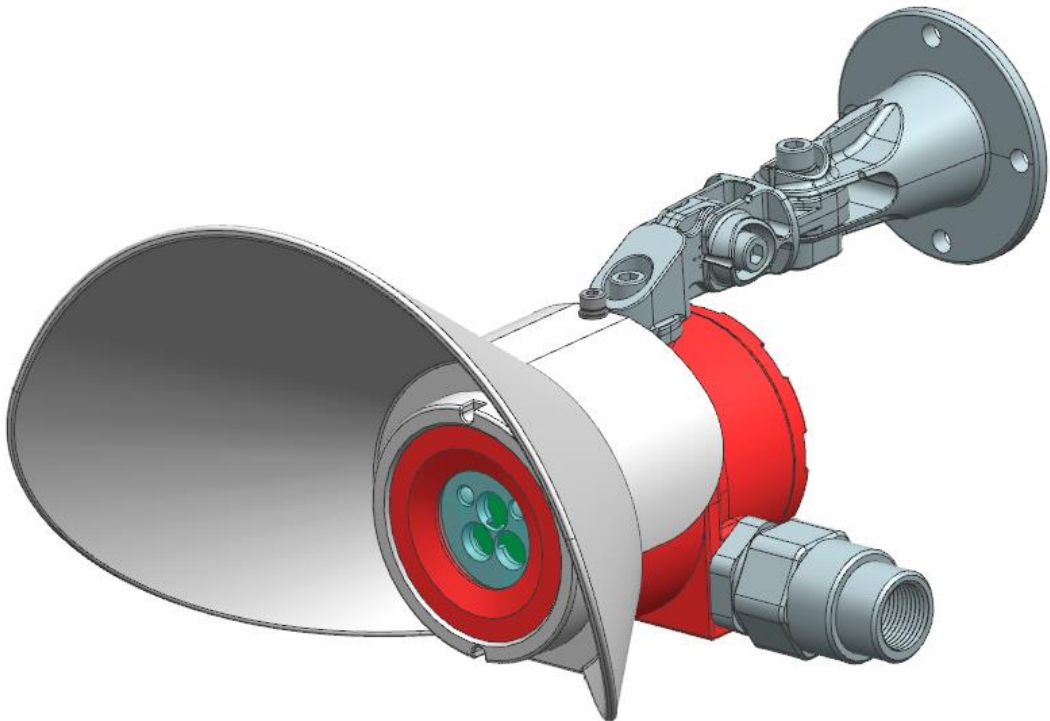
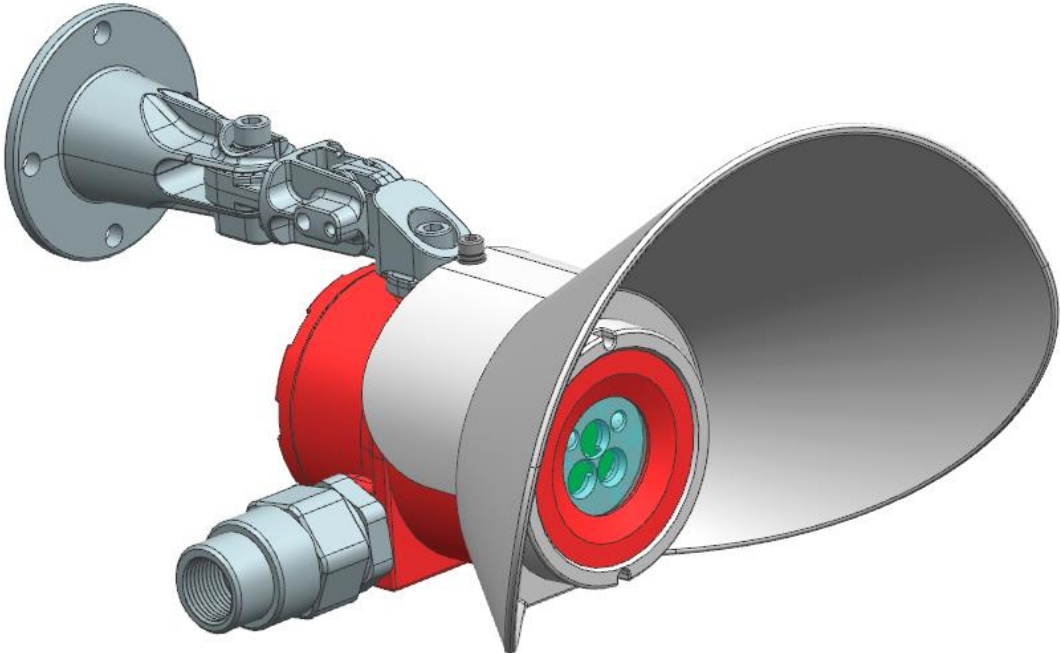
Direction	Figure
<p>Seen from the front of detector Right</p>	
<p>Seen from the front of detector Left</p>	

[Table 26: Cable Grand]

12. Precautions during Installation

When installing, places that can bring electrical harm (such as rain) should be avoided. As GTF-1100T requires periodic maintenance, it is also recommended to install in places where work can be done easily. As places with vibrations and impacts may influence on the output value, these places should be avoided and install so that sensor parts face the direction of gravity.

- FM
 - This device has explosion protection construction, it falls under Class I II III which includes gases and dusts and fibers in general business and chemical plant, and it may be used in Division 1 Group ABCDEFG Hazard Area.
- ATEX/IECEX/NEPSI
 - This device has explosion-proof construction, it falls under GROUP II which includes gas and vapor in general business and chemical plant, and it may be used in Zone 1-1 Hazard Area and Zone 2-2 Hazard Area.

It should be used in ambient temperatures:

FM	ATEX/IECEX/NEPSI
$T6 = -40^{\circ}\text{C} \leq T_a \leq 60^{\circ}\text{C}$ $T5 = -40^{\circ}\text{C} \leq T_a \leq 75^{\circ}\text{C}$	$T6 = -40^{\circ}\text{C} \leq T_a \leq 60^{\circ}\text{C}$ $T5 = -40^{\circ}\text{C} \leq T_a \leq 75^{\circ}\text{C}$ $T4 = -40^{\circ}\text{C} \leq T_a \leq 85^{\circ}\text{C}$ $T80^{\circ}\text{C} : -40^{\circ}\text{C} \leq T_a \leq 60^{\circ}\text{C}$

- Installation altitude: Below 1,000m above sea-level.
- Relative humidity: Up to 95% RH (Non-condensing)
- Installation place: Indoors and outdoors
- When working on wiring connection, explosion protection cable grand should be used at cable inlet, or when working on metal wire pipes, in order to prevent propagation of flame through wire conduit while gas lamp is moving or in explosion within 50mm, wire conduit must be sealed. Only products which passed safety certification must be used for all materials and materials used to close unused conduit.
- Other: Operate in situations that satisfy conditions of [Standards for selection, installation and maintenance of explosion protection construction electric machinery and device wiring, etc. in place of business].

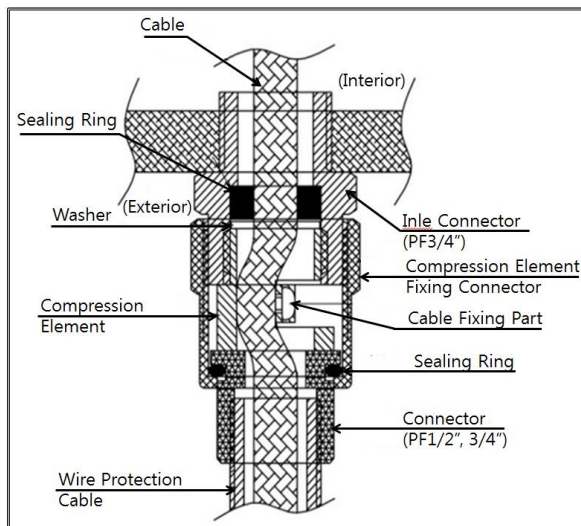

[Figure 21: Pressure Packing Type]

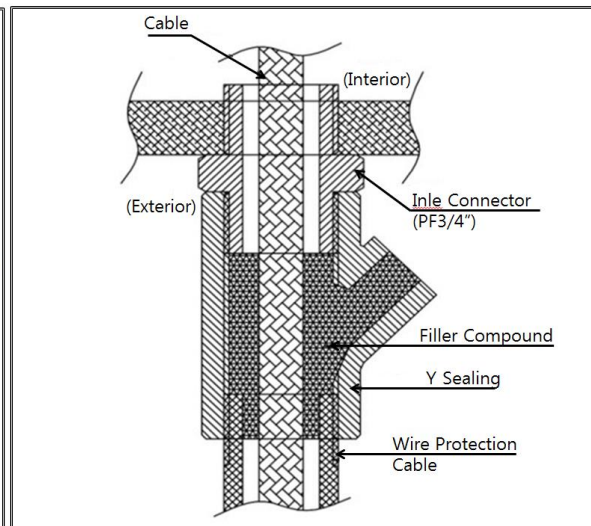

[Figure 22: Y Sealing Compound]

13. Warning

- Use cables rated 20K greater than the maximum ambient temperature.
- The equipment includes flame path joints, consult with the manufacturer if repair of the flame path joints is necessary.
- Under certain extreme circumstances, exposed plastic (including powder coating) and unearthened metal parts of the enclosure may store an ignition-capable level of electrostatic charge. Therefore, the user/installer shall implement precautions to prevent the buildup of electrostatic charge, e.g. clean with a damp cloth.
- Do not open when an explosive atmosphere is present.
- Seal all conduits within 18 inches.
- The purchaser should make the manufacturer aware of any External effects or Aggressive substances that the equipment may be exposed to.

14. Safe Use

- Flameproof joints are not intended to be repaired.
- The impact tests carried out on the glass windows were at 2J, therefore this equipment shall only be installed in locations where there is a low risk of impact damage.
- The maximum working temperature of the cable for field wiring shall be no less than 110°C

- When used in the presence of combustible dust, the end user shall remove the dust regularly to prevent the accumulation of the dust on the external surface of the housing, however it shall not be swept by compressed air.
- Do not rub the housing with a dry cloth or install in a high velocity dust laden atmosphere.

15. Revision Records

Version	Contents	Date
1.0	Initial Manual Revision	2018.10.22.
1.1	Revised by Ex Marking	2019.01.21.
1.2	Revised by another Ex Marking	2019.01.24.
1.3	Revised by Correct Typos	2019.01.30.
1.4	Revised by Ex Marking	2019.07.11.